

Report on  
Earthquake Reconnaissance of  
*The M7.8 Gorkha, Nepal Earthquake on  
April 25, 2015 and its Aftershocks*

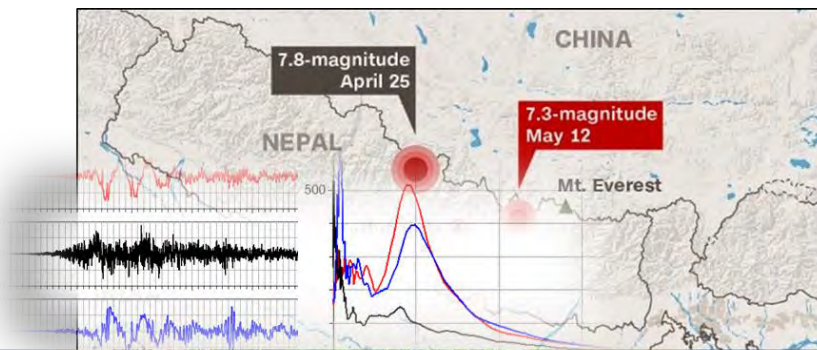

Canadian Association of Earthquake Engineering (CAEE)  
*L'Association Canadienne du Génie Parasismique*  
**Reconnaissance Team**

2017



# REPORT ON EARTHQUAKE RECONNAISSANCE OF THE M7.8 GORKHA, NEPAL EARTHQUAKE ON APRIL 25, 2015 AND ITS AFTERSHOCKS

Cover: Reconnaissance Team: Upul Atukorala, John Pao, Bishnu Pandey,  
Pablo Riofrio Anda, Svetlana Brzev, Robert Culbert and Sheri Molnar

Copyright © 2017 Canadian Association of Earthquake Engineering,  
Vancouver Canada

Published by: Canadian Association of Earthquake Engineering

ISBN: 978-0-9685376-2-6



*Disclaimer*

*The observations and opinions described in the individual papers of this Report are those of their contributing authors only and do not necessarily reflect the viewpoint of CAEE/ACGS.*

## PREFACE

The devastating Gorkha Earthquake and aftershocks which struck Nepal in April of 2015 caused tragic loss of life, serious injuries and disastrous damage. More than 9,000 people were killed, over 22,000 were injured and at least thousands of people were left homeless. Many more suffered great hardships. Overall, 2,649 public buildings and 510,762 private dwellings collapsed, while 3,617 public buildings and 291,707 private dwellings suffered partial damage. More than 7,000 school buildings and 1,085 healthcare facilities suffered damage (GON, 2015 B). The earthquake also affected approximately 2,900 structures with cultural and heritage values.

The Canadian Association for Earthquake Engineering (CAEE/ACGS) sent a team of engineers and geoscientists to study the impact of this earthquake and to explore the areas for technical cooperation between the Canadian and Nepalese earthquake engineering communities during the rebuilding process. The visit to the earthquake affected areas took place from June 10 to 20, 2015 and included visits to Kathmandu, Kavrepalanchowk, Sindhupalchowk, Dolakha, Dhading, Nuwakot and Rasuwa. This report presents the findings and observations from this visit.

The nine sections of this report provide the background for the above observations and are a source of other lessons and warnings. They offer preliminary information on seismological aspects; geotechnical observations; damage observed at the international airport, and damage suffered by concrete, masonry and vernacular stone building structures. Lessons for Nepal and Canada are also discussed at the end of the report. It should be recognized that this reconnaissance report provides only a preliminary description of the observed damage and, of necessity, is incomplete in both the aerial extent of its coverage, due to the small size of the team and its limited time in the field.

The Reconnaissance Team consisted of seven members and included consultants and academic researchers. The Team was joined by four Nepalese engineers, most of them from the National Society for Earthquake Technology–Nepal (NSET). The team also coordinated their activities with the Earthquake Engineering Research Institute (EERI) reconnaissance mission and had a briefing of their observations. The reconnaissance team presented their initial findings obtained from field observations to the Nepalese government. This was coordinated by the Ministry of Federal Affairs and local development. The CAEE/ACGS is grateful for the time and effort which all of these individuals devoted to the task of gathering and preparing the material for this report.

The reconnaissance visit was sponsored by the CAEE/ACGS, the Earthquake Engineering Research Facility at The University of British Columbia and the British Columbia Institute of Technology. Financial support provided by all sponsoring organizations is gratefully acknowledged.

July 2017



Carlos E. Ventura  
President, CAEE/AC  
Professor & Director of EERF  
Department of Civil Engineering  
The University of British Columbia

## Table of Contents

Title Page	1
Disclaimer	2
Preface	3
Table of Contents	4
Reconnaissance Team	8
CAEE Reconnaissance Visit	9
Acknowledgements	10

## The Reports

1	Gorkha (Nepal) Earthquakes 2015: An Overview	11
1.1	<i>Earthquake and Aftershocks</i>	11
1.2	<i>Earthquake-Induced Damage and Losses</i>	12
1.3	<i>Seismic Hazard and Vulnerability Context</i>	13
1.4	<i>Building Codes in Nepal</i>	14
1.5	<i>References</i>	15
2	Seismological Aspects and Observations of the M7.8 Gorkha Earthquake and M7.3 Aftershock	17
2.1	<i>Tectonic Setting and Historical Seismicity</i>	17
2.2	<i>The 2015 Gorkha Earthquakes</i>	18
2.3	<i>Observations--Damage and Ground Motion Intensities</i>	19
2.4	<i>Potential Site Effects</i>	22
2.5	<i>References</i>	24
3	Geotechnical Aspects of the Earthquake: Field Observations	25
3.1	<i>Geotechnical Aspects of the 2015 Gorkha (Nepal) Earthquake</i>	25
3.2	<i>Introduction</i>	25
3.3	<i>Geology</i>	26
3.4	<i>Observations</i>	27
3.4.1	<i>Bishnumati Bridge</i>	27
3.4.2	<i>Lokanthali Road Slump</i>	28
3.4.3	<i>Airport Runway</i>	29
3.5	<i>Fuel Storage Tank Farm and Fire Water Pits</i>	30
3.5.1	<i>Storage Tanks</i>	30
3.5.2	<i>Fire Water Pits</i>	31
3.6	<i>Guheshwori Waste Water Treatment Plant</i>	31
3.7	<i>Balaju and Gongobu Guest Houses</i>	33
3.8	<i>Landslides</i>	34
3.9	<i>Summary</i>	34
3.10	<i>References</i>	35
4	Impact and Response at the Tribhuvan International Airport, Kathmandu	36
4.1	<i>The Tribhuvan International Airport (TIA) as a Lifeline for an Earthquake Event</i>	36
4.2	<i>Seismic Challenges of the Existing Airport Infrastructure</i>	37
4.3	<i>The Airport Emergency Response Plan</i>	38
4.4	<i>Effects on the Existing Infrastructure of the TIA Airport</i>	40

4.5	<i>Concerns Raised by the Nepal Aviation Authorities</i>	40
4.6	<i>Plans to Improve and Modernize the TIA Airport</i>	41
4.7	<i>Timeline for the Implementation of the Proposed Projects</i>	41
4.8	<i>Summary</i>	42
5	<b>Urban Housing: Performance of Reinforced Concrete Buildings</b>	43
5.1	<i>Overview</i>	43
5.2	<i>Low-Rise Reinforced Concrete Buildings</i>	44
5.2.1	<i>Construction practice</i>	44
5.2.2	<i>Building Codes: Seismic Design Provisions</i>	46
5.2.3	<i>General damage observations</i>	46
5.2.4	<i>Inadequate detailing of RC structural components and poor construction quality</i>	47
5.2.5	<i>The effect of structural irregularities</i>	49
5.2.6	<i>Shear or flexural failure of RC frames with infills</i>	55
5.2.7	<i>“Weak column-strong beam” flexural failure mechanism</i>	56
5.2.8	<i>Shear-failure mechanism</i>	57
5.3	<i>Medium-Rise Reinforced Concrete Buildings</i>	60
5.4	<i>Summary</i>	62
5.5	<i>References</i>	62
6	<b>Rural Housing: Performance of Vernacular Stone Masonry Buildings</b>	64
6.1	<i>Background</i>	64
6.2	<i>General Damage Observations</i>	66
6.3	<i>Delamination of thick stone walls</i>	69
6.4	<i>In-plane shear failure of masonry piers</i>	69
6.5	<i>Out-of-plane wall failure</i>	70
6.6	<i>Roof-to-wall and floor-to-wall connections (wall bearing)</i>	71
6.7	<i>The effect of horizontal bands</i>	74
6.8	<i>Performance of stone masonry buildings with seismic provisions</i>	77
6.9	<i>Improving earthquake safety of stone masonry for post-earthquake reconstruction</i>	79
6.10	<i>Summary</i>	81
6.11	<i>References</i>	81
7	<b>Performance of School Buildings</b>	82
7.1	<i>Introduction</i>	82
7.2	<i>Vulnerability of School Buildings and Seismic Upgrading in Nepal</i>	82
7.3	<i>Performance of Conventional School Buildings Compared to Residential Houses</i>	85
7.4	<i>Performance of School Buildings with Seismic Upgrades</i>	86
7.5	<i>Performance of Reinforced Concrete Frame School Buildings</i>	88
7.6	<i>Major Contributing Factors to Severe Damage of RC School Buildings</i>	89
7.7	<i>Performance of Conventional Stone Masonry School Buildings</i>	91
7.8	<i>Non-structural Damage in Schools</i>	92
7.9	<i>Use of Schools as Community Shelters in the Aftermath</i>	94
7.10	<i>Summary</i>	95
7.11	<i>References</i>	<b>Error! Bookmark not defined.</b>
8	<b>Performance of Cultural Heritage Buildings</b>	96
8.1	<i>Overview</i>	96
8.2	<i>Swayambhu</i>	98
8.3	<i>Kathmandu Durbar Square</i>	104
8.4	<i>Summary</i>	111
8.5	<i>References</i>	111

9	The 2015 Gorkha, Nepal earthquake: Lessons for Nepal and Canada	113
9.1	<i>Lessons for Nepal</i>	113
9.1.1	Seismology	113
9.1.2	Geotechnical Engineering	113
9.1.3	Transportation/Airports	114
9.1.4	Non-engineered and pre-engineered low-rise RC buildings (designed according to MRT)	114
9.1.5	Engineered medium- and high-rise RC buildings	114
9.1.6	Non-engineered unreinforced masonry buildings	115
9.1.7	Schools	116
9.1.8	Heritage structures	116
9.2	<i>Lessons for Canada</i>	116
9.2.1	Seismology	116
9.2.2	Transportation/Airports	116
9.2.3	RC buildings	117
9.2.4	Unreinforced masonry buildings	117
9.2.5	Schools	117
9.2.6	Heritage structures	117





## Reconnaissance Team

### CAEE Team Members:

Bishnu Pandey, Ph.D. (Team Leader) Department of Civil Engineering, BCIT (Structural Engineering) - Rural construction, school safety

Svetlana Brzev, Ph.D., P.Eng., Department of Civil Engineering, BCIT (Structural Engineering) – Masonry and reinforced concrete structures, heritage buildings, reconstruction and retrofit

John Pao, P.Eng., Struct. Eng., S.E., Bogdonov Pao Associates Ltd. (Structural Engineering) – Reinforced concrete structures

Upul Atukorala, Ph.D., P.Eng., Golder Associates (Geotechnical Engineering) – Impact on geo and lifeline structures

Sheri Molnar, Ph.D., University of Western Ontario (Engineering Seismology) – Seismological aspects of the earthquake, field testing with micro tremor measurements

Pablo Riofrio Anda, Federal Aviation Administration, USA (Civil Engineering) – assessment of airports and lifelines

Robert Culbert, P.Eng., Builders without Borders (Civil Engineering) – Recovery, non-engineered buildings, housing, schools

### Local Nepalese Team Members:

Ramesh Guragain, Ph.D., NSET (Structural Engineering) – Building code, masonry structures, seismic retrofitting, Lead from Nepal side

Gokarna Bahadur Motra, Ph.D., Institute of Engineering, Tribhuvan University (Structural Engineering)

Youb Raj Poudel, Ph.D., Department of Education, Govt. of Nepal (Geotechnical Engineering)

Dev Maharjan, MSc., NSET (Structural Engineering) –Reinforced concrete structures  
Sujan Raj Adhikari, MSc. NSET (Engineering Geology)

### Other CAEE Members Contributing to the Study:

Carlos Ventura, Ph.D., P. Eng., P.E., University of British Columbia (UBC), Vancouver, Canada

## CAEE Reconnaissance Visit

The Canadian Association for Earthquake Engineering (CAEE) sent a team of engineers and geoscientists to study the impact of the April 25, 2015, Nepal Earthquake and to explore the areas for technical cooperation between Canadian and Nepalese earthquake engineering communities during the rebuilding process. The visit took place from June 10 to 20, 2015 in earthquake-affected areas, including Kathmandu, Kavrepalanchowk, Sindhupalchowk, Dolakha, Dhading, Nuwakot and Rasuwa.

The visit had the following two objectives:

- i. Study the earthquake rupture and the impact of the earthquake on built environment, and
- ii. Identify areas for further research and technical cooperation.

The team focused on several technical areas related to seismology, geotechnical and structural engineering, and education including:

1. Ground motion characteristics and relationship to the damage patterns in Kathmandu Valley and rural areas.
2. Site effects and site period identification techniques.
3. Seismic performance of residential and institutional buildings.
4. Performance of retrofitted buildings, and conceptual solutions for restoration and retrofit of non-engineered buildings.
5. Damage to heritage buildings and retrofit and restoration options
6. Vulnerability characterization of masonry buildings based on observed damage patterns.
7. Impact of building code implementation.
8. Reconstruction and recovery process.
9. Learning about accomplishments in communication of known seismic hazard and earthquake mitigation and planning (pre- and post-earthquake)

The CAEE team worked together with the Nepalese engineering team coordinated by the National Society for Earthquake Technology–Nepal (NSET). The team also coordinated with the EERI reconnaissance mission and obtained a briefing of their observations. The reconnaissance team presented their initial findings obtained from field observations to the Nepalese government coordinated by the Ministry of Federal Affairs and local development.

Upon completion of the visit, the CAEE team presented their findings in a special session in the 11<sup>th</sup> Canadian National Conference on Earthquake Engineering held in Victoria in July 2016. The team also presented the observations and study findings to several engineering and academia platforms including seminars separately conducted by Structural Engineers Association of British Columbia (SEABC), University of British Columbia (UBC), British Columbia Institute of Technology (BCIT) and the Masonry Institute of BC (MIBC).



## Acknowledgments

The reconnaissance visit was sponsored by the Canadian Association for Earthquake Engineering, the British Columbia Institute of Technology, and the UBC Earthquake Engineering Research Facility. Financial support provided by all sponsoring organizations is gratefully acknowledged.

The authors of the report acknowledge Garrett Nicol for proofreading and editing the report, and David Biggs, P.E., S.E. for providing invaluable feedback and input with regards to Section 7 of the report.

# 1 Gorkha (Nepal) Earthquakes 2015: An Overview

Bishnu Pandey<sup>1</sup> and Carlos Ventura<sup>2</sup>

## 1.1 Earthquake and Aftershocks

On April 25, 2015, Nepal was hit by an earthquake with the moment magnitude ( $M_w$ ) of 7.8 with the epicentre in Barpak village, Gorkha district, located about 80 km northwest of Kathmandu. The main event was followed by several large aftershocks with moment magnitude of 6.0 or higher. Three major aftershocks occurred within a few days of the main event, and these had  $M_w$  of 6.6, 6.9 and 6.8 respectively. An aftershock with  $M_w$  of 6.6 occurred on 25 April 2015 with the epicentre very close to that of the main shock, while the epicentres of the other major aftershocks were located east of Kathmandu. Within the first 12 hours of the main event, there were more than 120 aftershocks with  $M_w$  of more than 4.0. A more severe aftershock occurred on May 12, 2015, with  $M_w$  of 7.2 and the epicentre at Dolakha, about 100 km east of Kathmandu. Another major aftershock with  $M_w$  of 6.3 immediately followed the May 12, 2015, earthquake event. The focal mechanism of this major aftershock was similar to that of the main event. All aftershocks occurred in a narrow zone with a width of 40 km along the southern slope of the Himalayan mountain range. The fault rupture has a stretch of about 100 km, extending from Gorkha in the west of Kathmandu to Dolakha in the east. From the instrument recordings in Kathmandu, it was observed that the capital city witnessed mostly long-period shaking with peak ground acceleration (PGA) of about 0.16 g, and high ground displacements (maximum values of about 80 cm). This limited evidence explains why damage was mainly observed in low-rise buildings, such as unreinforced adobe buildings; heritage buildings, including century-old temples built of brick in mud mortar with timber elements; and non-engineered and poorly constructed reinforced concrete frame buildings with unreinforced masonry infills. However, some medium-rise reinforced concrete apartment buildings in Kathmandu were also severely damaged.

The 2015 Gorkha earthquake was the largest earthquake event in Nepal since 1934, when a devastating earthquake with  $M_w$  of 8.1 severely affected the country. The 2015 event was a low-angle thrust earthquake with very wide slipping area. The main shock caused intense ground shaking throughout Nepal, as well as in parts of India, Bangladesh and Tibet. The main shock and its major aftershocks severely affected several central Nepal districts mostly located in hilly regions, including the districts of Gorkha, Sindhupalchowk, Dolakha, Rasuwa, Nuwakot and Dhading. A peculiar observation with regards to the ground motion and the related earthquake damage is that the April 25, 2015, event affected more regions east of the epicentre than the regions west of the epicentre; this could be explained by the strong directivity effects of the fault rupture, which extended from Gorkha towards the east.

---

<sup>1</sup> British Columbia Institute of Technology (BCIT), Vancouver, BC, Canada

<sup>2</sup> University of British Columbia (UBC), Vancouver, BC, Canada

## ***1.2 Earthquake-Induced Damage and Losses***

The main event and its aftershocks caused a large number of casualties and damage to the built environment throughout Nepal and neighbouring countries—India, Bangladesh, China and Bhutan. The earthquake caused significant housing and infrastructure losses, and significantly affected the tourism and social, economic and cultural sectors. Post-Disaster Needs Assessment (PDNA) conducted by the Government of Nepal (GON, 2015 A) estimated that the direct economic loss due to the earthquake was on the order of CAN\$10 billion (US\$ 7.06 billion). Nearly 8 million people in Nepal were negatively affected by the earthquake.

The earthquake caused 9,256 deaths and another 22,300 people were injured in Nepal. A total of 850,000 houses were damaged by the earthquake. Overall, 2,649 public buildings and 510,762 private dwellings collapsed, while 3,617 public buildings and 291,707 private dwellings suffered partial damage. More than 7,000 school buildings and 1,085 healthcare facilities suffered damage (GON, 2015 B). The earthquake also affected approximately 2,900 structures with cultural and heritage values. Building typologies that were most severely impacted by the earthquake were low-rise unreinforced masonry buildings, including adobe buildings and rural stone masonry buildings constructed using mud mortar. Most affected areas were remote rural areas with stone masonry dwellings that were either severely damaged or collapsed due to the earthquake (see Figure 1.1). Reinforced concrete buildings with unreinforced masonry infills also collapsed in Kathmandu and other urban areas. These buildings had major design and construction flaws, and the construction quality was extremely poor. Out of all the buildings damaged in the earthquake, 58% were mud-based buildings (a category that includes stone masonry and adobe buildings), and another 21% were unreinforced brick or stone masonry buildings in cement mortar (Guragain et al., 2015).

One of the hardest hit sectors was livestock, which is a major income source for livelihood in rural areas. A total of 17,000 cattle and 40,000 smaller domestic animals were killed in the earthquake.

The earthquake impacted critical infrastructure systems, including 175 MW hydropower facilities, roads, water supply and irrigation facilities. Extensive road blockages (both major highways and other district roads) were mostly due to earthquake-induced landslides and permanent displacements (shifts) along the road sections. It should be noted that there was no major impact on the bridges. A total of 1,570 water supply systems (out of the total of 11,288 systems) sustained major damages throughout the country. The earthquake affected 290 small- and medium-scale farmer-managed irrigation canals.





*Figure 1.1: Extensive damage of rural stone masonry housing in Sindhupalchowk District (Photo: B. Pandey)*

### ***1.3 Seismic Hazard and Vulnerability Context***

Even before the 2015 earthquake, Nepal was well known as an earthquake hotspot, a country at high risk owing to its geological setting, its past events and the high vulnerability of its built environment. The country is located at the boundary of the Indian and Tibetan tectonic plates. Along the entire stretch, from east to west, the Indian plate is subducting under the Tibetan plate, giving rise to high seismic hazard throughout the country. The national seismic map shown in Figure 1.2 indicates that the country could experience the highest possible levels of shaking intensities, modified Mercalli intensities (MMI) of IX and X even within a 500-year return period. The tectonic setting has created a regular pattern of moderate-to-high earthquakes every 50 to 100 years. The most notable past earthquake occurred in 1934 with a magnitude (M) of 8.4, and it killed more than 8,000 people in Kathmandu alone. Similar earthquake events have occurred, on average, every 75 years in the densely populated Kathmandu Valley (GHI, 1999). A moderate 1988 earthquake of a 6.9 magnitude with the epicentre in Udayapur district in eastern Nepal killed 721 people and destroyed 65,000 buildings. More recently, in 2011 another earthquake of similar magnitude occurred along the border with India in eastern Nepal.

Considering the seismic hazard, the Himalayan region's earthquake history, the vulnerability of buildings and infrastructure systems, and the exposure of a large population, Bilham (2001) predicted the occurrence of a major earthquake within a relatively short time period. Other studies also ranked Nepal as one of the world's

countries at highest risk. Nepal is ranked the 11<sup>th</sup> most susceptible country in the world in terms of relative vulnerability to earthquake disasters by BCPR (2004). Similarly, the Global Earthquake Safety Initiative Pilot Project labelled the Kathmandu Valley as the highest risk city in terms of potential deaths in an earthquake (GHI and UNCRD 2001).

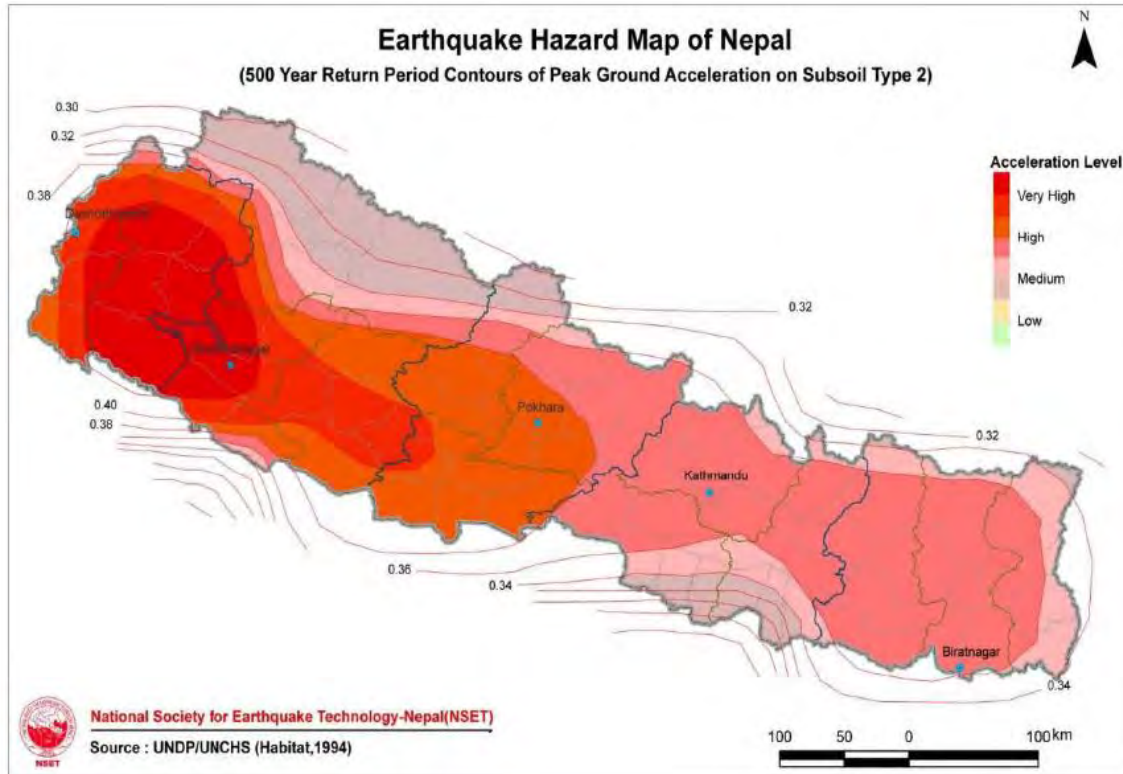

Source: UNDP/UN-Habitat, 1994

Figure 1.2: Seismic Hazard Map of Nepal

### 1.4 Building Codes in Nepal

In response to the 1988 earthquake, and in recognition of the high seismic hazard in the country, the Government of Nepal developed the first National Building Code (NBC) in 1994. The NBC included the code for earthquake-resistant design of buildings. The purpose of the NBC is to mitigate the effect of earthquakes on the buildings in Nepal (NBC000:1994). Accordingly, a building structure constructed in compliance with NBC “shall have sufficient strength so that the frequency of occurrence of structural damage is sufficiently low”, and it is “able to resist major earthquakes without collapse”. Local governments, especially municipal governments, were requested to comply with NBC under a law enacted in 2006 (12 years after the code was released). The NBC is supposed to be implemented through a building permit issuance process within municipalities. However, the code enforcement was not effective in most municipal areas throughout the country. The code is not mandatory in rural areas and is not applicable to vernacular buildings. At the national level, the Department of Urban Development and Building Construction (DUDBC), under the Ministry of Urban Development, acts as the national regulating agency responsible for ensuring compliance to NBC.

NBC has 23 volumes that collectively make up the code. The code classifies buildings under four categories with a separate set of compliance requirements for each category: (i) international state-of-the-art, (ii) professionally engineered structures, (iii) buildings of restricted size designed to “mandatory rules-of-thumb” and (iv) remote rural buildings. NBC does not require a third-party review of the “international state-of-the-Art” buildings. NBC 105:1994 prescribes the seismic hazard, basic analysis approaches and philosophy for seismic analysis and design. It deals mostly with professionally engineered structures. The third category “mandatory rules-of-thumb” (MRT) applies to low-rise buildings of restricted size and configuration, including reinforced concrete frames with masonry infills (NBC 201:1994). The MRT compliance requirements are aimed at the owner/builders for buildings which are not amenable to engineered analysis and rational design considerations. These buildings may be designed by sub-engineers (formally called overseers). Construction guidelines (NBC 203:1994) have been provided for ensuring seismic safety of the non-engineered rural buildings.

### **1.5 References**

Bilham R., 2001. Slow Tilt Reversal of the Lesser Himalaya between 1862 and 1992 at 78 deg. E, and Bounds to the Southeast Rupture of the 1905 Kangra Earthquake. *Geophys J Int.* 144:713–728.

BCPR, 2004. Global report – reducing disaster risk, a challenge for development. Geneva: United Nations Development Program. Bureau for Crisis Prevention and Recovery, 10 p (available from: <http://www.un.org/special-rep/ohrrls/lhc/Global-Reports/UNDP%20Reducing%20Disaster%20Risk.pdf>)

GeoHazards International, 1999. Kathmandu Valley Earthquake Risk Management Action Plan. NSET and GHI, Kathmandu, Nepal.

GHI and UNCRD, 2001. Global Earthquake Safety Initiative Pilot Project, Final Report, GeoHazards International and United Nations Centre for Regional Development, 86 p (Available from: [http://www.preventionweb.net/files/5573\\_gesireport.pdf](http://www.preventionweb.net/files/5573_gesireport.pdf))

GON, 2015A. Nepal earthquake 2015 – Post Disaster Needs Assessment – Volume A: Key Findings. Government of Nepal, National Planning Commission, Retrieved from <http://www.worldbank.org/content/dam/Worldbank/document/SAR/nepal/PDNA%20Volume%20A%20Final.pdf>

GON, 2015B. Nepal Earthquake 2015 Post Disaster Needs Assessment – Volume B: Sector Reports. Government of Nepal, National Planning Commission, Retrieved from [https://www.gfdrr.org/sites/gfdrr/files/WB\\_UNDP\\_PDNA%20Community\\_SP\\_FINAL.pdf](https://www.gfdrr.org/sites/gfdrr/files/WB_UNDP_PDNA%20Community_SP_FINAL.pdf)

NBC000: 1994, 1994. Nepal National Building Code, Ministry of Urban Development, Government of Nepal, Kathmandu, Nepal.



Guragain, R., Shrestha, S.N., Maharjan, D. and Pradhan, S. 2015. Building Damage Patterns of Masonry and Non-engineered Reinforced Concrete Buildings during April 25, 2015 Gorkha Earthquake in Nepal, Symposium proceedings of New Technologies for Urban Safety of Mega Cities in Asia, Kathmandu, Nepal.

## 2 Seismological Aspects and Observations of the M7.8 Gorkha Earthquake and M7.3 Aftershock

Sheri Molnar<sup>1</sup> and Sujan Raj Adhikari<sup>2</sup>

### 2.1 Tectonic Setting and Historical Seismicity

Active convergence of the continental Indian plate into the continental Eurasian plate (30-40 cm/year) has resulted in the highest elevated mountains, the Himalayas, in the world. Crustal shortening is accommodated by major thrust faults that strike east-west across Nepal. From south to north these major thrust faults are: main frontal, main boundary, and main central thrust faults, which are splay faults of the main Himalayan thrust fault between the two tectonic plates at depth.

Ten or more ‘great’ earthquakes, i.e., magnitude (M) 8 or greater, are known to have occurred along the Himalayan thrust zone from paleoseismic studies and historical records. Kathmandu has been significantly damaged by past great earthquakes (M 7.5 to 8.4) in the years 1255, 1344, 1408, 1681, 1833, and 1934 (Galetzka et al. 2015). The last great earthquake occurred in 1934 immediately east of Kathmandu resulting in ~10,000 fatalities. Recorded seismicity has demonstrated that the major shallow thrust faults are generally quiescent with earthquakes occurring in the overriding Eurasian plate ( $\leq 20$  km depth) as a band of seismicity in the lesser Himalayas (de la Torre et al. 2007). Deeper earthquakes occur at the base of the Indian plate (or top of the Moho) at 40 km depth at the collisional interface and at 80 km depth beneath the Himalayas (Monsalve et al. 2006). Hence, the main Himalayan thrust fault is currently locked and generates great M ~8 earthquakes at a recurrence interval of ~100s of years. Fig.2.1 shows estimated rupture zones of major Himalayan earthquakes.

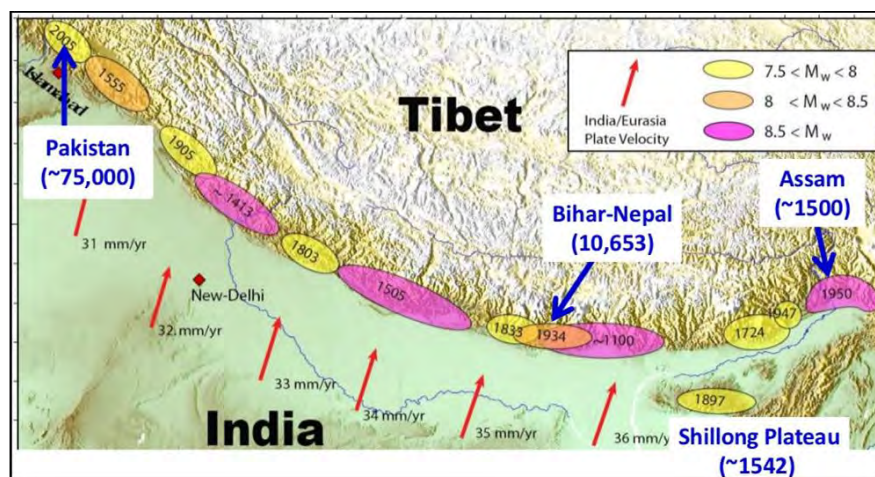

Figure 2.1: Estimated rupture zones of major Himalayan earthquakes ( $M > 7.5$ ) with fatality estimates labelled (from <http://www.asianinsurancereview.com/Portals/0/ImageLibrary/archivesAIR/2015/July/83-EstRapturedZone Himalayan.jpg>)

<sup>1</sup> University of Western Ontario, London, ON, Canada

<sup>2</sup> National Society for Earthquake Technology-Nepal (NSET), Kathmandu, Nepal

## 2.2 *The 2015 Gorkha Earthquakes*

From an examination of the areas and dates of past great earthquakes and review of their past damage (Bilham et al. 2001), a future great earthquake is expected to occur very near to Kathmandu, resulting in a catastrophe due to the combination of very high earthquake shaking and significant exposure of vulnerable buildings and population. The 25 April 2015 M 7.8 Gorkha mega-thrust earthquake therefore occurred in an anticipated location, 80 km NW of Kathmandu at a depth of 15 km, yet all other seismological considerations defied expectations. The shaking intensities and resulting damage in Kathmandu were generally lower than expected, resulting from the culmination of lower than expected magnitude, source frequency content, and blind-thrust rupture (i.e., rupture stopped at depth).

Inversions of worldwide seismic data (USGS and IRIS moment tensor solutions) demonstrated that the M 7.8 Gorkha earthquake is a thrust faulting event striking northwest-west with a shallow ( $7-10^0$ ) dip. The M 7.8 Gorkha earthquake was the first large continental megathrust rupture to have occurred beneath a high-rate (5-Hz) Global Positioning System (GPS) network (Galetzka et al. 2015). Rupture propagated unilaterally as a single  $\sim 6$ -sec duration pulse (Fig. 2.2), predominantly eastward (along strike) and slightly southward at  $\sim 3$  km/sec, taking  $\sim 35$ -sec for the first seismic P-waves to reach Kathmandu, and rupturing a full 150 km distance. Rupture also propagated slightly downdip. Slip was concentrated north of and at 10-15 km depth beneath Kathmandu; maximum slip of  $\sim 6$  m occurred east of Kathmandu (Galetzka et al. 2015; Wang and Fialko 2015). The Kathmandu valley rebounded upwards by  $\sim 1.0-1.5$  m and south by  $\sim 2$  m. Aftershocks highlight the main-shock rupture area. A second major event occurred on 12 May 2015 with a moment magnitude of 7.3, located at the eastern edge of the main-shock rupture zone.

Few strong-motion instruments were operating in Nepal at the time of the Gorkha earthquake. Mainshock peak ground acceleration (PGA) values at two strong-motion stations operating in central Kathmandu are: 0.16 g (USGS KATNP station; [www.strongmotioncenter.org](http://www.strongmotioncenter.org)) and 0.18 g (NSC DMG station; Bhattarai et al. 2015). For the M 7.3 largest aftershock, PGA values are 0.087 g (KATNP) and 0.12 g (DMG). In the deep lacustrine sediment of Kathmandu valley, the frequency content of the mainshock (Fig. 2.2) is predominantly 0.2-0.25 Hz (4-5 seconds), with site amplification occurring at 0.25-0.3 Hz (3-4 seconds) (Galetzka et al. 2015). Higher frequency ground motions were generated by the main shock north of Kathmandu, and by aftershocks (3-5 Hz) in Kathmandu.

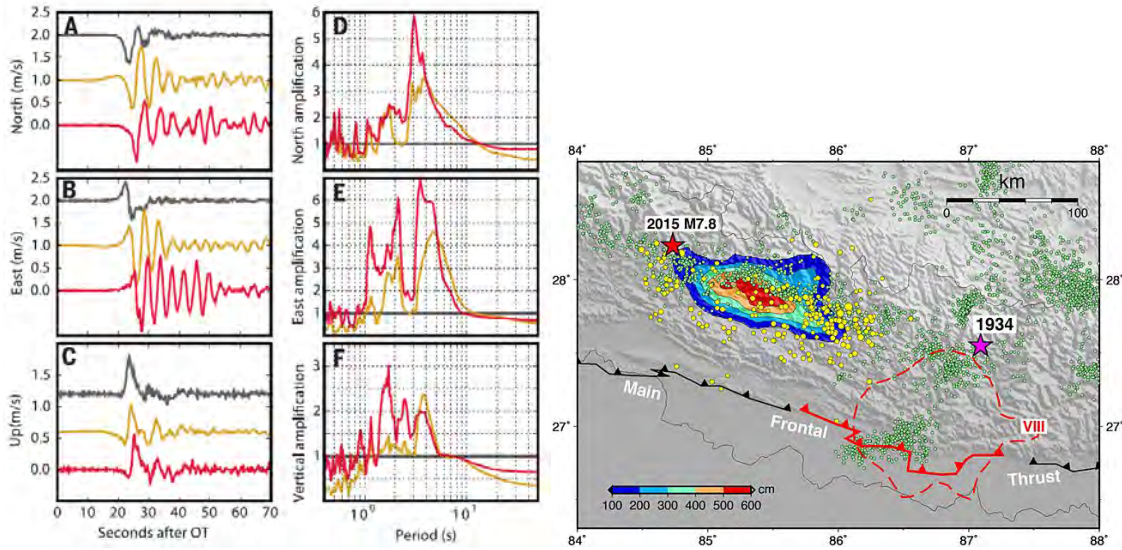

Figure 2.2: Left panel: Epicentre and coseismic slip (colours) of the 2015 Gorkha earthquake (from Wang and Fialko 2015; Fig. 5). Aftershocks (to 31 May 2015) shown by yellow circles and background seismicity (1995-2002) shown by green circles. Red solid and dashed lines represent the inferred surface rupture segment and isoseismal intensity of VIII of the 1934 Bihar-Nepal earthquake. Right panel: Three-component velocity records (A-C) of the 2015 Gorkha earthquake at a high-rate GPS hard rock site (KKN4; gray lines), and a high-rate GPS site (NAST; red lines) and strong-motion site (KATNP; orange lines) in the Kathmandu basin (from Galetzka et al. 2015; Fig. 3). Ground motion amplification (D-F) at the two basin sites relative to the hard rock site.

### 2.3 Observations–Damage and Ground Motion Intensities

Figure 2.3 shows locations visited by the CAEE reconnaissance team (red pushpins) and corresponding images of observed damage and ground motion intensity. The table below summarizes locations visited in and around Kathmandu during the 10-day CAEE reconnaissance mission and summarized observations. The CAEE team provided oral presentations of preliminary findings to ~150 Nepalese government officials (June 15<sup>th</sup>), and I attended a European-Nepalese (ITCP-NAST) academic workshop in Kathmandu (June 17<sup>th</sup>).



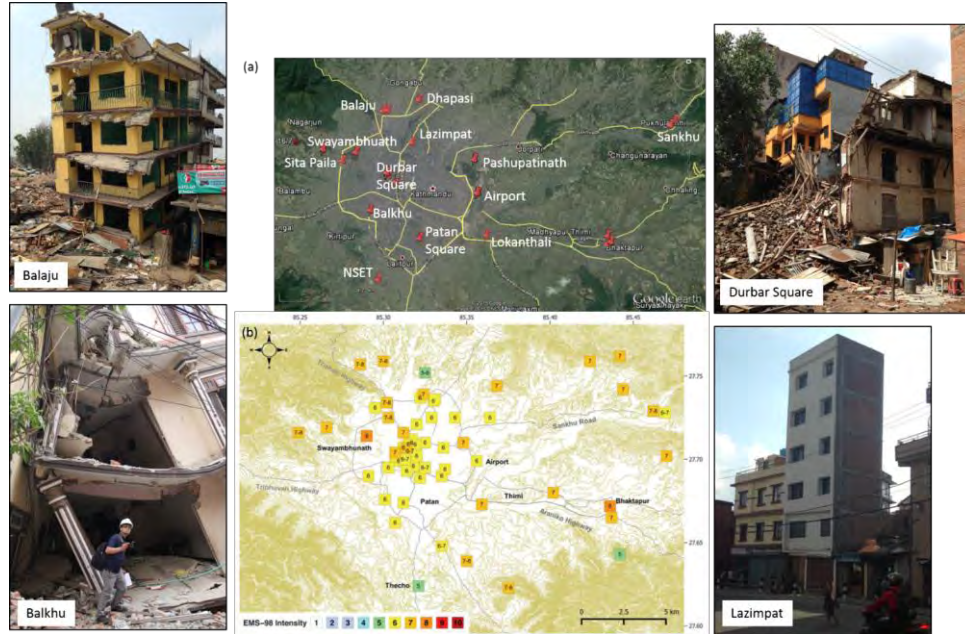

Figure 2.3: (a) Sites visited in and around central Kathmandu by the CAEE reconnaissance team marked by red pushpins (b) Macroseismic EMS-98 intensity map of the M 7.8 Gorkha earthquake (from Martin et al. 2015; Fig. 2)

Date	Location	Description and summarized observations
June 10	NSET, southern Kathmandu	Meeting at NSET with Nepalese collaborators. Minimal observed damage of residential buildings (cracks in walls) in neighbourhood.
	Balkhu, SW Kathmandu	Several collapsed buildings in neighbourhood. One building with collapsed upper floor. Several homes are significantly damaged.
June 11	Balaju, NW Kathmandu	West of Bishnubati bridge. Site comprised of four mid-rise ‘guest houses’ – two collapsed, third is leaning (lowest floor collapsed), with the fourth still upright and without observed damage(?). Ground is depressed (~2-m max. lower) than ring roadway but not sloping. Presence of soft-clay-lined holding ponds 50 m behind buildings. 75 fatalities; army arrived within 1 hr.
	Gungabu, NW Kathmandu	East of Bishnubati bridge. Pocket of collapsed buildings within ‘city block’. First floor of one building collapsed; building fell forward, now leaning on another building. A lady points out where she crawled out from. Active deconstruction occurring. Pancaked school in neighbourhood.
	Dhapasi, northern Kathmandu	Clay hill (~30-50 m) with recent complex of high-rise (17- storey) apartment buildings. Spalling of walls; X-pattern cracking observed in the lower 8 floors. Excavation (~2-floors) for underground parking.
	Sankhu village, ~15 km NE of Kathmandu	Across main road from Kathmandu, no observed damage of NSET retro-fitted school. Walk into the village: ~80% of buildings have collapsed. Dichotomy between primarily old masonry (collapsed) buildings and few recent concrete-frame (standing) buildings. Some streets still thick with rubble, some cleared. People living in tents, deconstructing, washing from water taps. One bulldozer.
June 12	Bhaktapur, ~12 km east of Kathmandu	UNESCO world heritage site – Main (durbar) square cleared and large heritage temples still standing (minimal damage), but every alleyway leading outward from square is full of rubble.

	Lokanthali, ~30 km east of Kathmandu	Differential settlement of highway; spans depressed ground (filled river channel; no surface water). Tilting (3°) of surrounding buildings with ~30-cm offsets; cracks in walls and roadway.
	Sita Paila, western Kathmandu	Two collapsed concrete buildings along ring road. Active deconstruction; hammering of bricks and concrete to strip out steel.
June 13	Dolakha district, ~75 km east of Kathmandu	Ten-hour round-trip drive to Dolakha district. Observe landslides, sections of highway cleared from debris, collapse of masonry homes. Meeting with district mayor; April earthquake not as damaging (5 fatalities) as May aftershock (2 km away). People sleeping outside, so low aftershock fatalities (1). District has 31,000 people and 7,000 buildings need reconstruction. Quick reconnaissance of 'old city'; terraced hillslopes and masonry 1-2 storey homes with damaged walls.
June 14	Airport, eastern Kathmandu	Microtremor testing at Kathmandu airport. Fuel tanks are ~8-m high; report of some spillage from sloshing. No cracks or offsets. No significant damage to airport runway; operating.
June 16	Swayambhuath hill, western Kathmandu	"Monkey Temple"; ~100-m rock outcrop. One of two circular shikas (free-standing columns) fell 'backwards' towards stupa and 'away' from steep front of hill. Significant damage to monastery masonry buildings; primarily women are carrying debris downhill in baskets on their backs.
	Patan, southern Kathmandu	Main Durbar square still closed. Walked around outer palace square. Temples or pagodas are generally still standing, minimal damage with wooden supports.
	Pashnupatinath, NE Kathmandu	No damage observed at sewage treatment facility.
June 18	Sindhupalchuk district, ~40 km NE of Kathmandu	Drive to Sindhupalchuk district; stopping at several ridge-top roadside villages. Generally tallest buildings built along main road with commercial soft-storey on sloping ground, which are leaning or collapsed (foundations on non-uniform ground). Commercial spaces are operating during day even in red-tagged or damaged buildings (merchants sleep in tents overnight). There are a few glass-front buildings with unbroken windows – suggests low shaking intensity.
June 19	Sita Paila, western Kathmandu	Differential settlement in residential complex beside creek. Most homes with minimal damage, few with significant damage (~2-cm shifting of foundation, large cracks in walls). Homes closest to creek on terraced mud. Concrete from homes is poor quality, easily breaks in hand.
June 20	Central Kathmandu	Dharahara Tower-area observer described tower as swaying north-south twice then east-west at which point it collapsed eastward. Down the street (~50-m north), out-of-plane wall failure at coin mint factory in same eastward direction as tower. Durbar Square area—again, some buildings have collapsed, while glass-front buildings are unbroken (low intensity?). Palace is significantly damaged (cracks and fallen bricks), but pagoda temples minimally damaged (wooden supports). Open to public and generally cleared of debris.

## 2.4 Potential Site Effects

Kathmandu is situated on a 500-600 m deep fluvio-lacustrine sedimentary basin underlain by metamorphic bedrock (Galetzka, et al. 2015). Microtremor (ambient vibrations) were performed in select locations in and around Kathmandu using ultra-portable three-component sensitive seismic sensors, called TROMINOs® (Figure 2.4). The TROMINO® is placed on the ground surface and a minimum of ~10 minutes of microtremors (ambient vibrations) are recorded and the average horizontal-to-vertical spectral ratio (HVSr) is calculated. The microtremor amplification spectra are indicative of underlying ground conditions; a single clear peak indicates a significant impedance contrast in the near-surface.



Figure 2.4: Photos of microtremor measurements performed in and around Kathmandu using ultra-portable TROMINO® sensors (small red sensors)

Four distinct “groups” of microtremor amplification spectra (HVSr) response are apparent in Figure 2.5:

- (a) Low amplification with generally broad single-peak response is observed at locations without reported damage in central (Lazimpat), southern (NSET), and eastern (Airport, Sewage Plant) Kathmandu. The HVSr response recorded at Lokanthali (highway settlement) is more similar to these non-damaged building sites in Kathmandu.
- (b) Distinct narrow single HVSr peaks with moderate to high amplification (factor of ~3-5) are determined at sites with significant observed damage in Kathmandu. A relatively high peak frequency of ~0.8-1.0 Hz is associated with sites in western Kathmandu in the Balagu-Gungabu area in the northwest, Sita Paila in the central west, and Balkhu in the southwest. In contrast, relatively low and broad amplification is determined at Dhapasi (damaged high-rise apartment complex).



- (c) Flat response (no amplification) is observed at terraced rock sites in Charikot, Dolhaka district (~75 km NE of Kathmandu; ~2500 m elevation), whereas broad amplification between 2-10 Hz is observed atop Swayambhuath hill (~100-m rock outcrop) likely due to near-surface jointing, fracturing, etc.
- (d) Distinct narrow single HVSR peaks with moderate-to-high amplification (factor of ~3-5) are determined at heritage sites in and outside of Kathmandu. The lowest peak frequency response (~0.3 Hz) is observed at sites in central Kathmandu, at or in the immediate vicinity of Durbar square and Dharahara Tower; Patan square to the south exhibits ~0.4 Hz response. In the Bhaktapur area, ~0.5 Hz peak response is observed. In Sankhu village, the relatively high frequency response (~1.0-1.2 Hz) is similar to significant building damage in western Kathmandu (Fig. 2.5b).

(a) Minimal damage locations

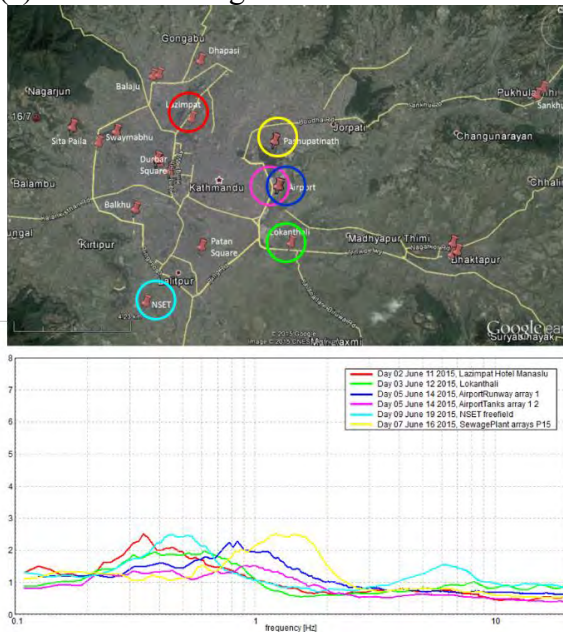

(b) Significant damage locations

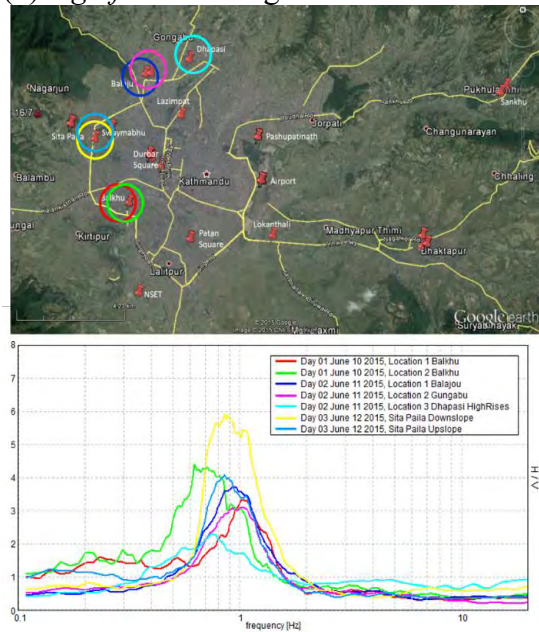



I Topographic (hill) sites

(e) Heritage sites

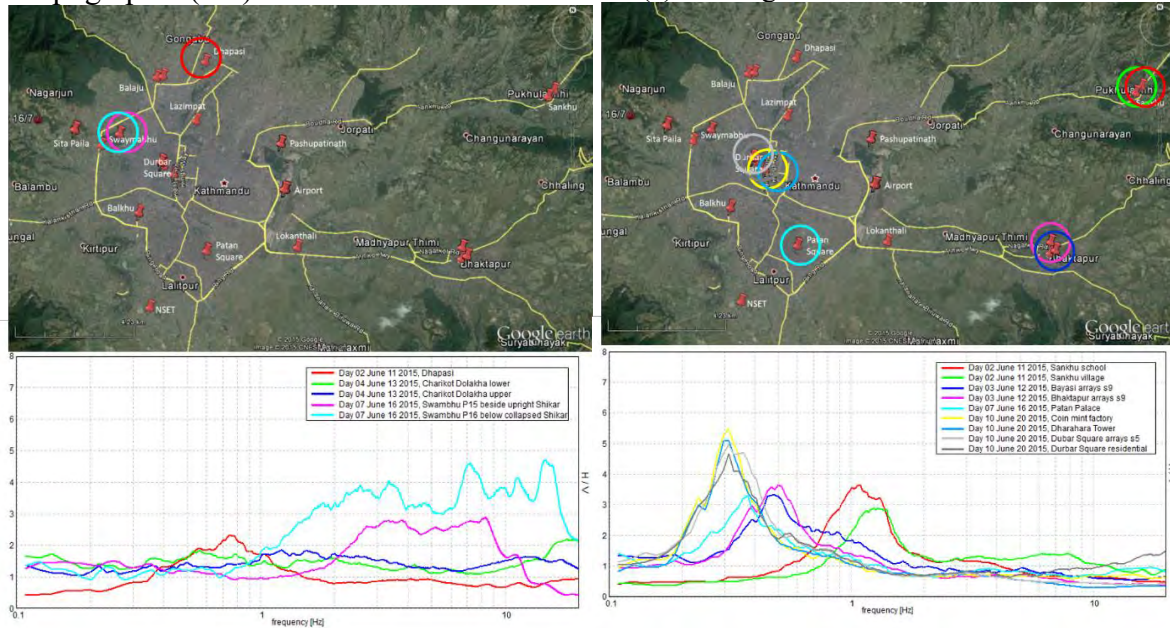

Figure 2.5: Microtremor HVSR response (amplification vs. frequency plots) measured in locations (a) of minimal and (b) significant observed damage in Kathmandu, as well as (c) at topographic hill and (d) at heritage sites around Kathmandu. Colour corresponds to circled locations shown in above maps.

## 2.5 References

Bhattacharai et al. 2015. Overview of the Large 25 April 2015 Gorkha, Nepal, Earthquake from Accelerometric Perspectives, *Seis. Res. Lett.*, 86, 6, 1540-1548.

Bilham et al. 2001. Himalayan Seismic Hazard, *Science*, 293, 1442-1444.

De la Torre and Sheehan, 2015. Broadband Seismic Noise Analysis of the Himalayan Nepal Tibet Seismic Experiment, *Bull. Seis. Soc. Am.*, 95, 3, 1202-1208, doi: 10.1785/0120040098.

Galetzka et al. 2015. Slip pulse and resonance of the Kathmandu basin during the 2015 Gorkha earthquake, Nepal, *Science*, 349, 6252, 1091-1095.

Monsalve et al. 2006. Seismicity and one-dimensional velocity structure of the Himalayan collision zone: Earthquakes in the crust and upper mantle, *J. Geophys. Res.*, 11, B10301, doi:10.1029/2005JB004062.

Martin et al. 2015. Ground Motions from the 2015 Mw 7.8 Gorkha, Nepal, Earthquake Constrained by a Detailed Assessment of Macroseismic Data, *Seis. Res. Lett.*, 86, 6, 1524-1532.

Wang and Fialko, 2015. Slip model of the 2015 Mw 7.8 Gorkha (Nepal) earthquake from inversions of ALOS-2 and GPS data, *Geophys. Res. Lett.*, 42, doi:10.1002/2015GL065201.

## 3 Geotechnical Aspects of the Earthquake: Field Observations

Upul Atukorala<sup>1</sup>

### 3.1 *Geotechnical Aspects of the 2015 Gorkha (Nepal) Earthquake*

This chapter describes the geotechnical aspects of the 2015 Gorkha (Nepal) earthquake. Some of the key observations on foundation performance made during the field reconnaissance carried out over the period extending from June 10<sup>th</sup> to June 16<sup>th</sup>, 2015 are presented herein. Following discussions with the members of the National Society for Earthquake Technology (NSET) in Nepal and to minimize the risk of repeat efforts by the many interested parties visiting Nepal after the earthquake to the same areas of damage, the site reconnaissance efforts were focused on selected areas of Kathmandu, supplemented with an out-of-town visit to Dolakha District. Considering the time that had elapsed since the occurrence of the M7.8 main shock (on April 25, 2015) and the M7.3 main aftershock (on May 12, 2015), visible ground damage was somewhat limited with repairs already underway at most sites. Some of the information presented herein is based on discussions the author had with the occupants of structures and with contractors and is based also on approximate measurements made on site features.

### 3.2 *Introduction*

The M7.8 Gorkha earthquake that occurred on April 25, 2015 induced measured Peak Ground Accelerations (PGA) of about 0.16 g in Kathmandu (Station KATN). This measured peak horizontal ground surface acceleration was comparatively low for an earthquake of this magnitude. This level of ground shaking is understood to be about 35% of the intensity of the design earthquake shaking in Nepal.

Processing of seismograph data (communications with Dr. Adams) indicate that the 0.16 g PGA is associated with a peak horizontal ground velocity close to 1 m/s, with a peak ground displacement of about 2 m occurring over a period of some 4 to 5 seconds. The recorded motions are indicative of some 2 to 3 effective cycles of strong shaking. For more details on the level of shaking inferred from instrumental records, refer to Chapter 2.

The earthquake occurred during a relatively dry period in Nepal, some 2 months before the start of the monsoon season. Although the author was not successful in securing any direct data on the depth of water table that existed at the time of the earthquake in the different sites visited and described in the proceeding sections, it is anticipated that the water table would have been deep, possibly in the range of 5 to 9 m below the existing ground surface.

---

<sup>1</sup> Golder Associates Ltd, Vancouver, BC, Canada

### 3.3 Geology

The Kathmandu Valley is surrounded by high-rising mountains to the north and to the south. The valley is underlain by thick semi-consolidated fluvio-lacustrine sediments composed of clay, locally referred to as “black clay”. The sediments vary in thickness from 400 to 600+ m and they are underlain by coarse sand and gravel beds. The lacustrine sediments are primarily derived from the mountains surrounding the valley via the ancient drainage channels. The deeper coarse sand and gravel have been formed by the Bagmati River drainage system.

Published maps showing the geology of the Kathmandu Valley as well as liquefaction susceptibility of soils underlying the valley are available from the published literature (ref. Piya, 2004). Figures 3.1 and 3.2 show the geology map reproduced from Piya (2004) and a schematic cross-section of the Kathmandu Valley reproduced from Pokhrel, et al. (2015) and Sakai, et al. (2002), respectively.

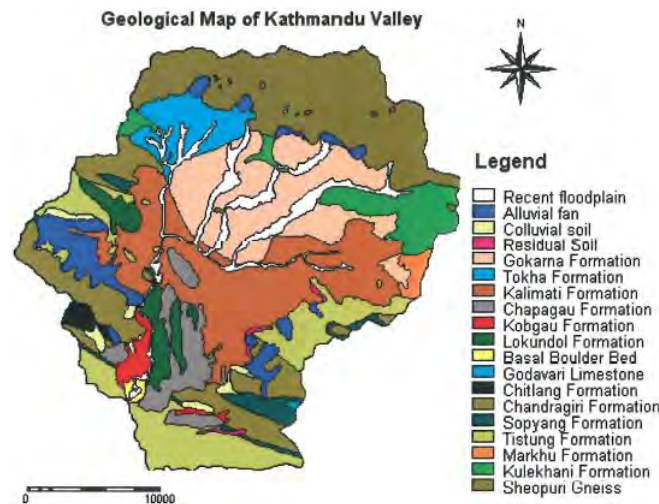

Figure 3.1: Geology map for Kathmandu Valley (ref. Piya, 2004 and Department of Mines and Geology)

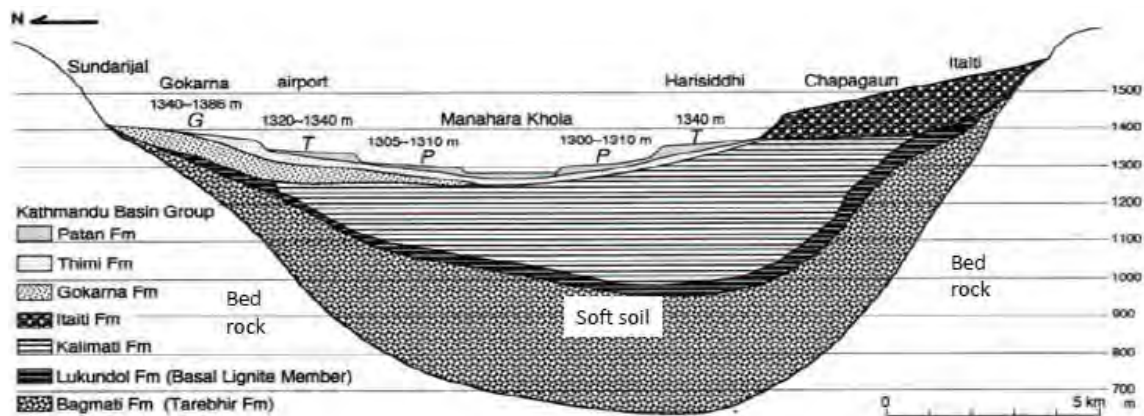

Figure 3.2: Schematic cross-section of the Kathmandu Valley  
 Note: approximate vertical exaggeration = 10  
 (Ref. Pokhrel et al, 2015 and Sakai et al, 2002)



The author understands that some 250 deep boreholes (>100 m depth) and 100 shallow boreholes (between 45 and 100 m depth) have been drilled in the valley for water-well exploration. These boreholes describe the soil stratigraphy encountered at each location in sufficient detail. However, they do not contain penetration resistance measurements with depth for engineering characterization of the site.

The Kathmandu Valley has a warm and temperate climate with maximum temperatures in the order of 30 to 32 degrees Celsius in summer (April) and 1 to 3 degrees in winter (January). The valley records an above-average annual rainfall of the order of 1400+ mm/yr. The Bagmati, Bishnumati and Manahara rivers drain the valley with an outlet in the southeast through the Chobhar Gorge (cf. Piya, 2004).

### 3.4 Observations

The following sections present a summary of the observations made on the geotechnical aspects of site and/or foundation performance during the site reconnaissance.

#### 3.4.1 Bishnumati Bridge

Bishnumati Bridge is an approximately 80-m-long, 11-m-wide, 4-span and 2-lane concrete girder bridge crossing the relatively narrow Bishnumati River on Tahachali Road. The bridge is supported on three river bends each in turn supported on what appears to be 4 to 5 drilled shafts. According to the geology map for the area, the site is underlain by the Kalimati Formation comprising up to 450 m of silty clay and clayey silt (Figure 3.3). The year the bridge was built is not known.



Figure 3.3: Geological formation at the bridge site

The bridge was functional with unrestricted traffic flow. No movements of the river banks or the piled river bents were visible to the naked eye (Figure 3.4). There were, however, signs of the bridge being subjected to longitudinal movements during strong ground shaking as seen from compressional cracking and rotation of the abutments (Figure 3.5).



Figure 3.4: Substructure view  
June 11, 2015



Figure 3.5: Damage to abutment  
June 11, 2015

### 3.4.2 Lokanthali Road Slump

One of the notable earthquake-shaking-induced road slumps occurred in Lokanthali along the Araniko Highway. The area is underlain by the Gokarna Formation that consists of laminated and poorly graded silty sand. An estimated 200-m-long section of the highway slumped due to cyclic softening of foundation soils and associated lateral spreading. Local settlements of up to 1 m have occurred in the sloping areas of the highway embankment (ref. Pokrel et al, 2015).

Low-rise structures located in the general area surrounding the road slump also indicate settlement and tilting following strong shaking from the earthquake. Permanent lateral displacements of the order of 0.2 to 0.3 m along with 3 to 4 degree tilting of the structures were common (Figures 3.6, 3.7, and 3.8).



Figure 3.6: Road slump (after repair)



Figure 3.7: Local settlement



Figure 3.8: Permanent lateral movements and tilting of structures

### 3.4.3 Airport Runway

The Tribhuvan International Airport (TIA) is located in a terraced area underlain by the Gokarna Formation comprising 300 m or more of laminated and poorly graded silty sand (Figures 3.9 and 3.10). The Manahara River is located to the east and south of TIA and the Bagmati River is located to the west and north of TIA. Due to the terraced nature of the overall site, the depth to the groundwater table is expected to be deep.

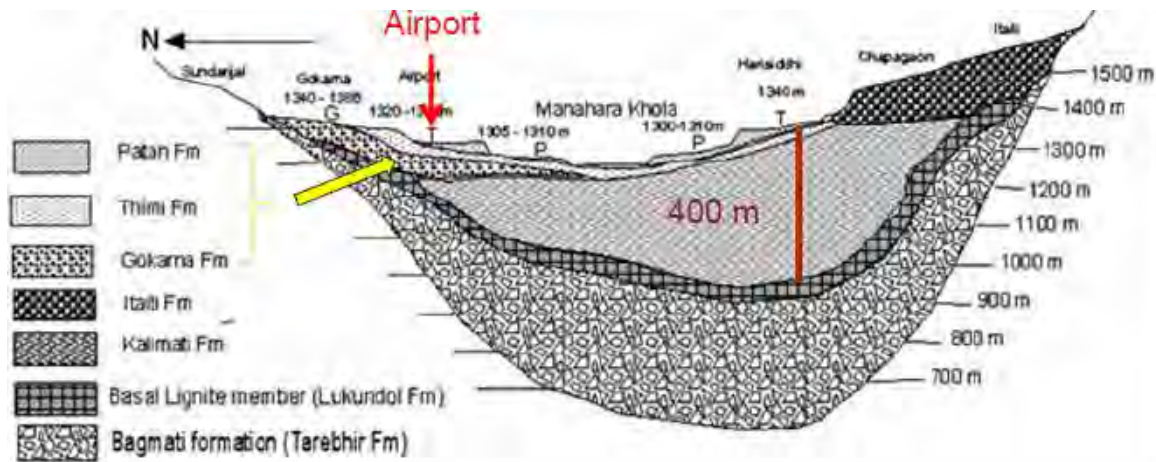

Figure 3.9: Geology and approximate site topography at TIA



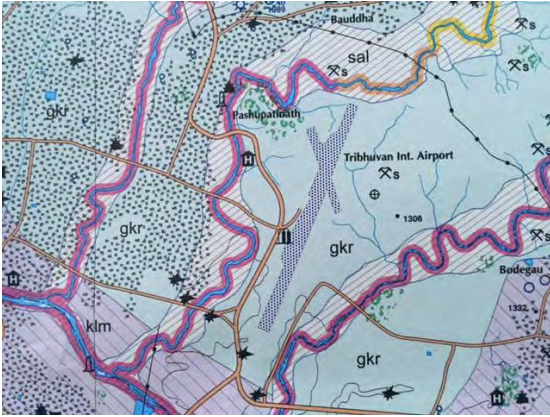

Figure 3.10: Site geology



Figure 3.11: Airport runway in operation  
June 14, 2015

No disruptive damage was observed in the airport runway other than some minor cracking. The runway was operational without any restrictions (Figure 3.11).

### 3.5 Fuel Storage Tank Farm and Fire Water Pits

#### 3.5.1 Storage Tanks

A series of 5 above-ground jet fuel storage tanks are located to the west of the TIA runway in a terraced area underlain by the Gokarna Formation described earlier in Section 3.4.3. Three out of the five tanks are located in a terrace that is some 2 to 2.5 m below the runway elevation with the remaining 2 tanks located in a separate terraced area that is 2 to 2.5 m lower than the first terrace. It is estimated that the tanks are 8-10 m in height and 6-8 m in diameter (see Figures 3.12 and 3.13). All tanks are supported on concrete slab foundations that protrude about 1 m outside the tank footprint and some 0.3 m above the surrounding ground surface. Based on discussions with onsite personnel, it is understood that the concrete foundations are in turn supported on a well-compacted granular mat that is about 1 m thick. All 5 tanks have been recently painted and were in



operation at the time of the site reconnaissance.

*Figure 3.12: Three storage tanks in the upper terrace, June 14, 2015*

*Figure 3.13: Foundation of tank June 14, 2015*

No damage was visible in the tank foundations or the piping connected to the tanks at the bottom or the elevated walkway connecting two of the tanks. However, based on discussions with a contractor who was performing some repair work in the adjoining fire water pits, it is understood that some 20 kilo litres of oil spilled out of the tanks during strong shaking due to sloshing.

### 3.5.2 Fire Water Pits

Two fire water pits are located in between the tank areas and in the upper terrace. The pit walls of the tanks are constructed out of unreinforced cement mortar bricks with the perimeter walls raised about 0.6 to 0.9 m above the surrounding ground surface. Some damage was visible to the above-ground portions of the pit wall. It appears that part of the wall has fallen inside the pit and construction workers were in the process of bailing out the pit walls (Figure 3.14). No damage



*Figure 3.14: Repairing the fire water pit walls*

## 3.6 Guheshwori Waste Water Treatment Plant

The Guheshwori Waste Water Treatment Plant (WWTP), which is understood to be one of the 5 WWTPs in Kathmandu, Nepal, is located immediately northwest of TIA. Figure 3.15 shows locations of WWTPs in the Kathmandu metropolitan area. The processed water is discharged to the Bagmati River, which is one of the major Kathmandu rivers flowing towards the north and northeast. According to the geological maps available, the treatment plant is underlain by Gokarna Formation consisting of laminated and poorly grade silty sand deposits that extend to depths of 300 m or more.

This activated sludge treatment plant serves an effective area of 5 km<sup>2</sup> and has the capacity to treat 17 million litres of sewage per day.



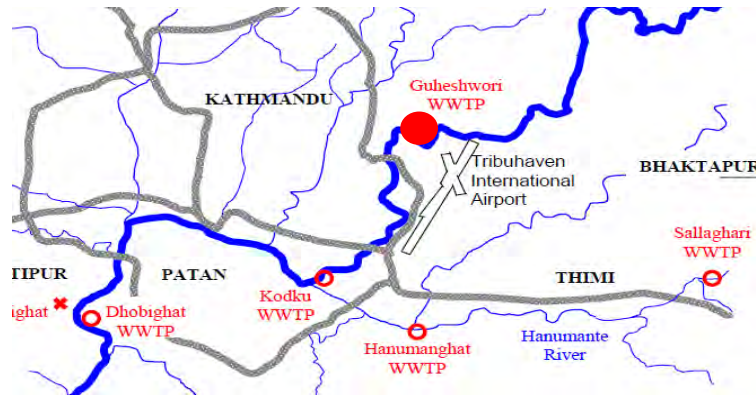

Figure 3.15: Locations of the WWTPs in Kathmandu (Ref. Green et al, 2003)

At the time the site reconnaissance was carried out, the plant was in full operation. Discussions with plant personnel confirmed that the plant did not suffer any major damage or interruption of service due to the earthquake.

No visible geotechnical damage was noted in the foundations supporting the major structures comprising the treatment plant, connecting pipelines or in any of the affiliated support structures (Figures 3.16 and 3.17).



Figure 3.16: Secondary clarifiers  
June 14, 2015



Figure 3.17: Connecting pipelines  
June 14, 2015

The only visible reportable damage consisted of some minor structural damage to the walls of the rectangular sludge treatment tanks (Figure 3.18).



Figure 3.18: Collapsed parts of the vertical walls of the sludge treatment tanks

### 3.7 Balaju and Gongobu Guest Houses

A large number of medium-rise guest houses (5-to-6 storeys high) constructed in the Balaju and Gongobu areas experienced significant damage following the April 25, 2015, main shock (Figure 3.19). The buildings were not in a repairable state and were in the process of being demolished at the time of the site reconnaissance. The speculation amongst the engineering community in Nepal is that the damage was the result of foundation failure. The on-going demolition work and mounds of rubble in the immediate vicinity of the buildings prevented a detailed examination of the foundation failure modes.

The available geological maps indicate that this area is underlain by the Gokarna Formation. Some limited information available from a water-well drill hole indicate 2 m of silty clay, followed by 12 m of gravelly sand, followed by 4 m of sand, followed by 33 m of clay sand followed by a thick layer of clay.

A combination of foundation failure and soft-first-storey damage may have led to the significant damage experienced by these 5-to-6 storey non-engineered structures.



Figure 3.19: Severely damaged guest houses in Balaju and Gongobu, June 11, 2015 (a.k.a. Bus Park)

### 3.8 Landslides

The steep mountainous terrains in Nepal inevitably lead to high risk of landslides when subjected to strong ground shaking. The April 25<sup>th</sup> earthquake and the subsequent aftershocks induced a large number of small-to-large-scale landslides and rock falls killing people and, in some cases, blocking sections of major highways. A detailed account of the re-activated and new landslides resulting from the Gorkha earthquake can be found in GEER (2015). It is fortunate that the earthquake occurred during a relatively dry period, some two months before the start of the main monsoon season in Nepal, because relatively dry soil conditions with a deep water-table are unlikely to trigger a large number of small-to-large-scale landslides.

Our team observed several small landslides both on the way to and inside Dolakha on June 13, 2015. They are considered to be representative of failure of soil masses in steep terrain due to strong ground shaking (Figures 3.20 and 3.21).



Figure 3.20: Soil failure in steep terrain  
June 13, 2015



Figure 3.21: Soil failure, Dolakha District  
June 19, 2015 (credit: B. Pandey)

### 3.9 Summary

The geotechnical damage caused by the 2015 M7.8 Gorkha earthquake was limited. It was fortunate that the horizontal PGAs and the number of cycles of significant shaking experienced were comparatively low for an earthquake of this magnitude. The lack of geotechnical damage can be explained by the unusually low level of strong shaking—the smaller number of cycles of strong shaking—in combination with a deep groundwater table that likely existed at the time of the earthquake.

If the earthquake-induced larger PGAs had been closer towards the design values (of the order of 0.45 g), if there had been a larger number of effective cycles of strong shaking corresponding to the established correlations with the magnitude of the earthquake, and if wet/saturated site soil conditions had existed in the valley, it is the author's assessment that more widespread and destructive geotechnical damage would have occurred in Kathmandu Valley.



### ***3.10 References***

Pokhrel R. M., Chiaro G., Kiyota T, Katagiri T, Goda K., and Sharma, K (2015), Preliminary Damage Survey Report on 2015 Nepal Gorkha Earthquake, PowerPoint Presentation, [www.eqclearinghouse.org](http://www.eqclearinghouse.org).

GEER Association Report No. GEER-040 (Version 1.0), July 29, 2015, Geotechnical Field Reconnaissance: Gorkha (Nepal) Earthquake of April 25, 2015 and Related Shaking Sequence.

Piya, B. K. (2004), Generation of a Geological Database for Liquefaction Hazard Assessment in Kathmandu Valley, Master of Science Thesis, International Institute for Geo-Information and Earth-Observation, Enschede, The Netherlands.

Green, H., Po, S.C., Richards, A. (2003) Wastewater treatment in Kathmandu, Nepal, Master of Engineering in Civil and Environmental Engineering, MIT.

Adams, John (2015) Personal Communications on Recorded Ground Motions After Nepal Earthquake.

## 4 Impact and Response at the Tribhuvan International Airport, Kathmandu

Pablo Riofrio Anda<sup>1</sup>

### 4.1 *The Tribhuvan International Airport (TIA) as a Lifeline for an Earthquake Event*

If there is a facility that could be considered a lifeline during a catastrophe, it is the Kathmandu International Airport, also known as Tribhuvan International Airport (TIA). The Kathmandu Valley suffers from a severe lack of transportation infrastructure; therefore, as the only international airport of Nepal, the Kathmandu airport constitutes the only option for receiving aid, distributing relief goods and evacuating injured and stranded victims.

From the point of view of aviation operations, the TIA airport demonstrates important limitations: The only runway of the airport is relatively short for the large aircraft most commonly utilized to transport such relief resources as rescue workers, medicines, food and water. Due to years of uninterrupted operations, this runway is in need of serious revamp and maintenance, but operations allow only a few hours per night to complete the required maintenance and repairs. These light maintenance procedures could only allow for the surfacing of the runway and unfortunately have not allowed for a complete refurbishing of the base and sub-base.

In addition, the design of the TIA airfield was for smaller, lighter aircraft than for the present-day commercial demand; therefore, the airfield pavement suffers from years of overloading. Since the need for continuous operations of the only international airport in Nepal does not allow for a proper repair of projects, most of the maintenance projects have consisted of asphalt overlays. In some areas of the airfield, there is more than a meter of asphalt placed over the years.

Other major limitations for the operation at TIA is the length and location of the only available parallel taxiway. This important feature of the airport, does not match the length of the runway and does not offer the required separation for the operation of the larger wide-body aircraft. This limitation forces the airport to stop all other movements on the ground while a landing operation is taking place.

During a major event like the past Gorkha earthquake, airports undergo a very large increase in the number of operations and the type of operations. These increased operations deliver additional damage to the runway and in general to the rest of the airfield. Two weeks into the rescue operations for the Gorkha earthquake, the TIA

---

<sup>1</sup> Federal Aviation Administration, USA

management was forced to restrict the landing weight of aircraft to avoid further damage to the airfield.

The Nepal authorities appreciate the liability of having a “single airport” as a lifeline in the event of a national disaster and presently are working on developing Lumbini and Pokara as alternative airfields capable of diversifying the response operations.

#### ***4.2 Seismic Challenges of the Existing Airport Infrastructure***

Besides its geometric and operational restrictions, the TIA airport has other important challenges from the seismic point of view. Most of the airfield and terminals are built on fill with a fluctuating water table level that changes with the seasons. These conditions promote several liquefiable pockets at the airfield that were not identified prior to 2012. Unfortunately, such key facilities as the fuel farm, and the airport rescue and firefighting facility are located on potentially liquefiable areas. There is also a section of the runway that is vulnerable due to liquefiable soils (see Figure 4.1).

The existing domestic terminal is very susceptible to damage, since the facility was not built observing seismic considerations.

As previously demonstrated by several post-earthquake reports, the Gorkha earthquake did not behave as predicted by the several seismic studies completed for the Kathmandu Valley (among others, JICA – The Study on Earthquake Disaster Mitigation report of 2002). The peak ground acceleration measured for the Gorkha earthquake was 0.16g—only a third of the predicted peak value of 0.45g. This reduced ground shaking, combined with the fact that the Gorkha earthquake occurred during the dry season, resulted in overall damages that were less severe than forecast.

This situation was auspicious for the TIA airport facilities that only experienced minor damage to the operating and critical facilities. The runway and parallel taxiway suffered only a minor crack perpendicular to the fuel farm facility. However, the crack is small and does not represent an operational hazard; therefore, the TIA airport continues operating with the same busy schedule as before the Gorkha earthquake.

As mentioned before, the airfield was damaged due to the overloading conditions of the rescue operation. There are several projects to repair the taxiway that suffered the most damage and continue the maintenance of the runway as before, until the new expanded facilities are implemented in accordance to the master plan of the TIA airport.

Surprisingly, the new domestic terminal facility suffered most of the visible damage at the TIA airport from the effects of the Gorkha earthquake. Unfortunately, the new domestic terminal, not yet in operation, shows many problems in the building details, lacking cross-bracing structures and introducing severe changes of geometry and stiffness for the top part of the columns supporting the roof, a design that makes the glass-curtain wall located in the roof structure very vulnerable to the excessive movement of the supporting structure, posing a large risk for the passengers below.

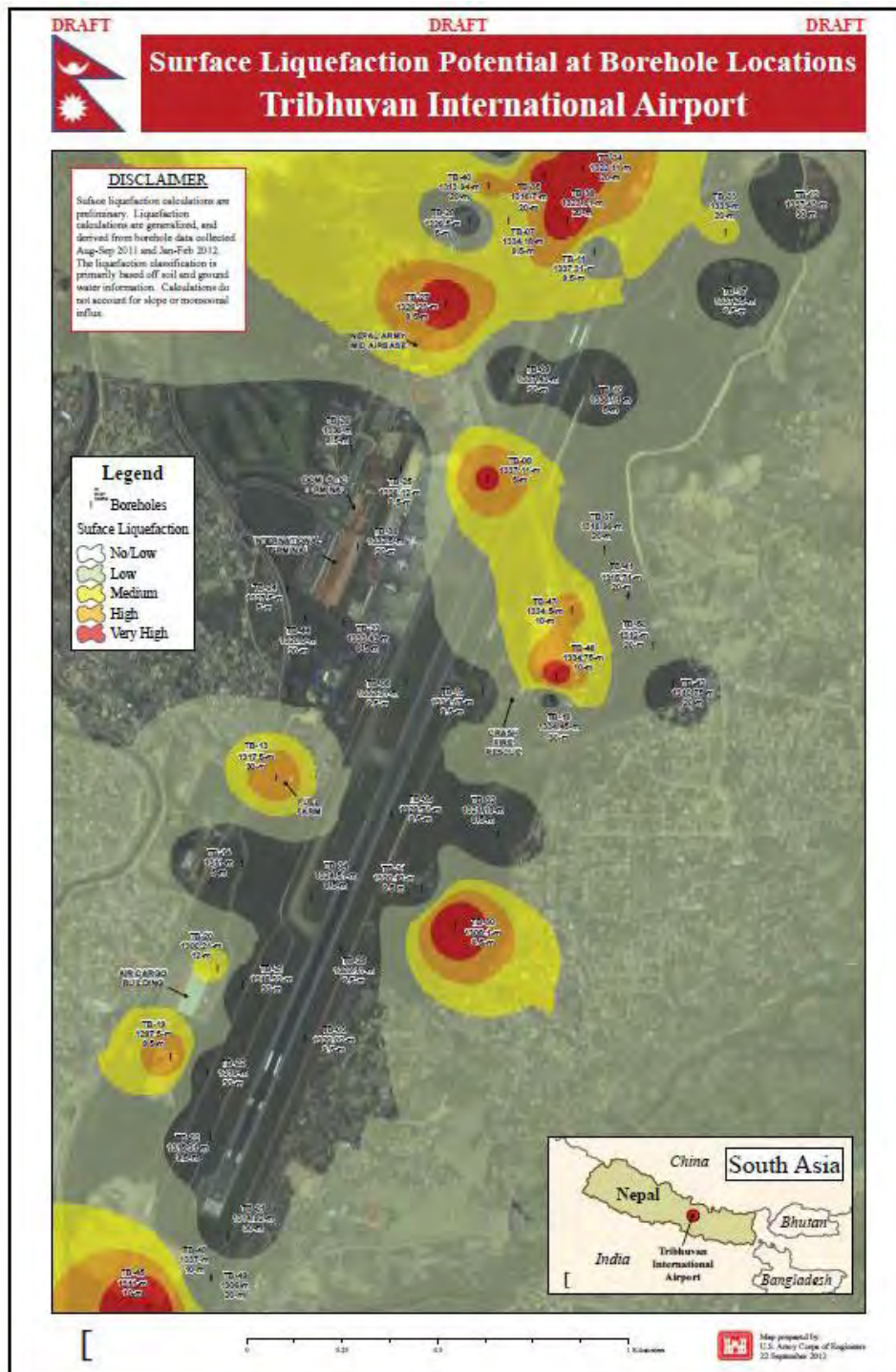

Figure 4.1: Surface liquefaction potential for Kathmandu International Airport

### 4.3 The Airport Emergency Response Plan

Since 2011 the US Army Corp of Engineers (USACE) has been funding projects to improve the resilience of the TIA airport. One of these initiatives was the development of the Tribhuvan International Airport Disaster Response Plan, with the goal of hardening

the critical facilities of the airport and developing a response matrix that identified the roles and responsibilities of all the stake holders at the TIA airport.

This plan has made a very positive contribution to organizing the response and the aid coming from abroad. The plan was completed with the participation of several organizations responsible for international disaster response. Among the participating organizations, a key contributor was the UN Logistic Cluster, acting as the organization in charge of arranging the receiving and distribution of aid. Often during a disaster, the international organizations and the government authorities of other countries that respond to a disaster send aid that may not be a priority or relevant for the disaster area, creating obstruction and congestion, especially at airport facilities that have limited space in the airfields.

As explained before, the TIA airport limitations decrease to a minimum the practicable number of operations per hour; therefore, it is paramount to make that reduced number of operations the most effective and efficient for the administration of the disaster response. The Thibuvan International Airport Disaster Response Plan addressed the need to classify and organize the type and priority of the aid and donations coming from other countries and organizations. The plan contemplates a throughput capacity that needs to be calculated regularly as the conditions of the airfield get back to normal, assigning to the UN Logistics Cluster the responsibility to clear the incoming flights with the most pertinent aid.

In addition, the USACE is completing several structural hardening programs that will make critical facilities more resilient to a disaster event. These projects are funded yearly in coordination with all other plans of the Civil Aviation Authority of Nepal (CAAN) for the improvement and modernization of the airport.

The Tribhuvan International Airport Disaster Response Plan was exercised in September 2014 with the participation of most of the stake holders. This exercise helped polish several aspects of the plan that turned out not as clear in the drill as anticipated in the written document. This practice was fresh in the memory of all participants at the time of the Gorkha earthquake occurrence; therefore, the implementation during the real event was more effective and competent than expected. CAAN and USACE identified several areas that require further refinement; however, the evaluation of the plan was a very auspicious 90% to 95% applicability.

USACE has completed a lessons-learned presentation highlighting the parts of the plan that worked and the parts that need future improvement to raise the efficiency and applicability of the plan.



#### ***4.4 Effects on the Existing Infrastructure of the TIA Airport***

The Tribhuvan International Airport Disaster Response Plan addresses several areas of improvement that the TIA authorities could develop as independent projects that will make the response plan more effective:

- the need to complete assessments and reports on the conditions of the facilities, developing a baseline to establish evaluation parameters for an after-event situation; evaluation after the event?
- rapid repair activities in case of runway or taxiway damage that creates large gaps that could reduce the length of the runway to less than 60% of the existing available length;
- increase of aircraft loading and unloading equipment, usually overwhelmed with the amount of cargo that requires speedy handling;
- availability of aircraft fuel at the existing fuel farm facility and the soundness of the fuel distribution system; the plan also focuses on the volume of fuel required for the calculated throughput capacity of the airfield and the need for temporary storage facilities and flying-tank requirements.
- increase the areas dedicated to aircraft parking, with special emphasis on the implementation of ramp space for parking heavy aircraft fuel tanks;
- locate all cables buried in the airfield that serve the navigational aids and visual aids of the runway system. There is a lack of as-built drawings, making any earth movement project in the existing airfield very risky for the continuity of these crucial elements of the landing and take-off operations of aircraft at TIA airport; and
- modify and improve the drainage areas adjacent to the runway and taxiway to avoid water infiltration to the base and sub-base structures.

#### ***4.5 Concerns Raised by the Nepal Aviation Authorities***

The CAAN and government authorities of Nepal are very concerned about the single infrastructure lifeline represented by the TIA airport and the vulnerability of the



- extension of international terminal building.

Unfortunately, this project is 24 months behind schedule, affected by several circumstances, including strikes and court cases for the supplying quarries and most recently the fuel crisis of Nepal. The fuel crisis may result in a default of the project due to force majeure.

All other phases of the master plan (marked in orange, green and purple in the master plan) are scheduled for commencement the first quarter of 2018. At the time of this writing, there is a contractor developing the design documents required to complete the works. The design and bidding documents should be available in July 2017; scheduling, bidding and selection of the contractor are planned for the end of 2017.

#### **4.8 Summary**

The TIA is the “lifeline” for Kathmandu. Unfortunately, there are no other alternatives to transport emergency aid or supplies to the Kathmandu Valley. Presently TIA is the only certified international airport serving Nepal.

The road network and bridges are in very precarious conditions. Most of the bridges are in dire need for important maintenance and repairs. Nepal does not have a railroad.

TIA airport has several challenges from the seismic resilience point of view. Several vital facilities for the airport are located in liquefaction-prone areas, e.g. the fuel farm; the firefighting station; the airport radar, etc. Presently there are several ongoing projects to increase the resilience of the airport and its throughput capacity.

Within their means the Government of Nepal is responding to the need to improve and diversify the transportation options for the Kathmandu Valley. These improvements should provide additional alternatives for receiving aid and increasing the commerce revenue for the country.

In the aviation sector, the Government in Nepal has secured loans to modernize and enlarge the existing TIA airport. The detailed design for the Master Plan described above shall be completed by the last quarter of 2017, with construction schedule to start in late 2018 or early 2019. In addition, the airport at Pokhara is undergoing airfield modifications and infrastructure expansion that will allow it to be certified for international commercial activity. Finally, at the moment the Government of Nepal is also implementing the construction of the green field Gautam Buddha International Airport near Lumbini in Western Nepal.

In the other transportation sectors, the Government in Nepal is implementing several bridges and roads upgrades to withstand the recurring flooding and other natural disasters, this will provide more reliable road connectivity to important supply centers like Kolkata, India, which is the nearest port for the Kathmandu Valley.

## 5 Urban Housing: Performance of Reinforced Concrete Buildings

Svetlana Brzev<sup>1</sup>, Bishnu Pandey,<sup>2</sup> and John Pao<sup>3</sup>

### 5.1 Overview

Reinforced concrete (RC) frame construction is the most prominent building typology both in urban and suburban areas of Nepal. This practice originally started in the late 1970s; however, the rate of construction increased after the 1988 Nepal-Bihar earthquake (magnitude 6.6), mostly due to poor performance of unreinforced masonry buildings in the earthquake. This trend is also associated with economic development in urban areas and such social factors as aspirations. Surveys of building construction in the Kathmandu Valley showed that, as of 2001, about 49% of buildings constructed within the last 10 years (i.e. built in the 1990s) were of RC construction, while only 11% of 20-to-30-year-old buildings (i.e. built in the 1970s) were of the same construction type (JICA, 2001). A skyline of Kathmandu showing typical RC buildings is shown in Figure 5.1.



Figure 5.1: Skyline of Kathmandu showing predominantly low-rise RC construction with masonry infills (Photo: Bishnu Pandey)

Most RC buildings in Nepal are of low-rise construction, and they are used as residential buildings for extended families, which is a common housing pattern in Nepal. Space at ground-floor level in these buildings is often used for commercial purposes (small stores). Also, many buildings of this type in Kathmandu region are hostels for workers from rural areas who have migrated to the capital region. In recent years, a few

<sup>1</sup> British Columbia Institute of Technology (BCIT), Vancouver, BC, Canada

<sup>2</sup> British Columbia Institute of Technology (BCIT), Vancouver, BC, Canada

<sup>3</sup> Bogdonov Pao Associates, Vancouver, Canada



medium-rise apartment complexes (mostly 10- to 15-storeys high) have been built in the Kathmandu area. These apartment buildings are usually inhabited by a high-middle-class population, while the remaining population lives in low-rise buildings. An overview of RC design and construction practice in Nepal and the observations related to performance of RC buildings in the 2015 earthquake will be discussed in the following text.

## 5.2 *Low-Rise Reinforced Concrete Buildings*

### 5.2.1 Construction practice

Most of these buildings are three- to five-storeys high, with 2.8 m floor height. These are mostly residential buildings, but there are also some hotels/hostels and commercial buildings of this type. Many buildings serve mixed functions, with ground floor used for commercial purposes and upper floors used for residential purposes. These buildings are known as storefront buildings and have one or two open sides in their plan, as shown in Figure 5.2. Open storefront buildings usually have a rectangular plan shape with variable plan dimensions. For example, one building we surveyed had a 20 m length and 10 m width. Typically, stores at the ground-floor level are 3-m-wide single rooms separated by brick masonry partitions. Fully residential buildings of this type usually have smaller plan dimensions, at 9 to 12 m in length and 6 to 8 m in width.



*Figure 5.2: RC buildings with open storefront typical for Kathmandu and other urban and suburban centres in Nepal (Photo: Svetlana Brzev)*

Most buildings of this type are characterized by one or more structural irregularities. For example, RC buildings with an open storefront are characterized by a torsional irregularity in the plan (due to the absence of walls on one or two sides). These storefront buildings are also characterized by a weak-storey irregularity, because the shear capacity of the bottom storey is less than that of the upper storeys due to wall discontinuity up the building height. Very often, the top floor in these buildings has a setback with a significantly smaller plan area than the lower floors, and it is considered as

a vertical geometric irregularity. A setback is considered as a half-floor. For example, a three-storey building with a setback at the top level is often referred to as “two-and-a-half-storey building”. A building with a setback is shown in Figure 5.3a).

Many buildings in hilly areas of Nepal are built on sloped ground and as a result have a vertical stiffness irregularity. As an example, these buildings are three- or four-storeys high at the top of the slope, but five- or six-storeys high at the bottom of the slope (Figure 5.3b).



Figure 5.3: Vertical irregularities in typical low-rise RC buildings in Nepal: a) building with a setback at the top floor level and b) a building on sloped ground in a hilly area (Photos: Svetlana Brzev)

The main seismic-force-resisting system in these buildings is RC frame with unreinforced brick masonry infill walls. RC floor and roof structures typically have 100 mm thick slabs. It was observed that column size was relatively small, that is, 227 mm (9 in) square; this size is recommended by MRT for three-storey buildings. Beams in these buildings are 227 mm (9 in) wide, while the depth ranged from 305 mm (1 ft.) to 425 mm (1 ft 5 in.). It appears that the buildings designed by engineers are characterized by deeper beams. RC columns and beams typically have 4 or more longitudinal deformed steel bars (variable sizes), while the transverse reinforcement was usually in the form of 7 mm diameter closed ties at 200 mm (8 in) spacing. (In some cases 5 mm wires were also observed.) In a majority of the buildings where ties were exposed, anchorage was provided by means of 90-degree hooks (as opposed to the 135-degree hooks that are required for ductile seismic performance). It was observed that two types of deformed steel bars were used: TOR steel (similar to Grade 400 steel used in Canada) and Torkari steel (Figure 5.4). It appears that the Torkari steel is more brittle due to different chemical composition (carbon content) than the TOR steel. Masonry walls were built using burnt clay bricks in cement mortar. It was observed that exterior walls were thicker (230 mm) than interior walls (115 mm). Typical brick compressive strength was 7 to 10 Mpa, and the mortar mix proportion ranged from 1:4 cement:sand for exterior walls to 1:6 cement:sand for interior walls.





Figure 5.4: Steel reinforcing bars used for RC construction in Nepal: Torkari steel (top) and TOR steel (bottom) (Photo: Svetlana Brzev)

### 5.2.2 Building Codes: Seismic Design Provisions

Most low-rise RC residential buildings were owner-built and were not designed by engineers; however, some commercial and institutional buildings of this type may have been designed by engineers who followed prescriptive provisions, known as Mandatory Rules of Thumb (MRT), which are outlined in the Nepal's National Building Code (NBC 201:1994). MRT are intended for pre-engineered design, where the sizes for key structural components, reinforcement details and standard design drawings are included. Rigorous seismic analysis and design are not required for construction of low-rise RC buildings (up to three-storeys high). These rules should be applicable only to regular buildings; however, in practice they have been used for the design of buildings with various irregularities and taller than three storeys.

According to the commentary of MRT, it is expected that masonry infill panels will act as shear walls and resist seismic forces during a moderate earthquake, but RC frames are expected to be effective in resisting seismic effects after these infill walls have suffered damage or collapse in a major earthquake.

### 5.2.3 General damage observations

Many low-rise RC buildings were exposed to the 2015 earthquake and its aftershocks. Fortunately, most of these buildings, especially those located in the Kathmandu area, remained undamaged. This could be expected based on the available acceleration records, which show that the Peak Ground Acceleration (PGA) in Kathmandu is on the order of 0.15g. This is considered to be significantly less than the design PGA (0.45g) for Kathmandu according to seismic design provisions of the Nepal National Building Code (NBC 105:1994). However, several RC buildings were affected by the earthquake, with the damage ranging from minor damage (cracks in the masonry walls and RC columns) to complete collapse of several buildings in Kathmandu and smaller communities located closer to the epicentre (e.g. Dolakha and Sindupalchok districts). It should be noted that severely damaged RC buildings in Kathmandu were

found at a few localized areas (pockets), and the damage was caused by higher intensity ground shaking at those locations. Note that buildings with similar construction features did not suffer any damage at some other locations in Kathmandu.

It is believed that the main causes of earthquake-induced structural damage in low-rise RC buildings were

- inadequate detailing of RC structural components and poor construction quality,
- increased seismic demand due to structural irregularities, and
- shear or flexural failure of RC frames with infills.

#### **5.2.4 Inadequate detailing of RC structural components and poor construction quality**

A few common reinforcement detailing flaws were observed in a majority of the damaged RC buildings, including: i) excessively wide tie spacing in RC columns (Figure 5.5a), ii) ties with 90 degree hooks (Figure 5.5b), and iii) and lap splices in longitudinal reinforcement at floor locations (and inadequate splice lengths) (Figure 5.5b). It was also observed that high strength steel (Torkari bar) was used for longitudinal reinforcement at many locations where fractured bars were observed (indicating tensile failure of the bars). It was also observed that ties were not provided at beam-to-column joints (Figure 5.5b). Several instances of poor quality of concrete construction, reflected by large-size aggregate (gravel) (Figure 5.5b) and large chunks of concrete (Figure 5.5b), were also observed. It is believed that these deficiencies contributed to significant damage and collapse of RC buildings that were located in the areas subjected to significant ground shaking.

Inadequate detailing of RC structural components and poor construction quality can be illustrated on an example of a collapsed 5-storey residential building of the 1990s vintage in the Khulesor area of Kathmandu (Figure 5.6). The column size was 305 mm (12 in.) square, and the beams were 305 mm (12 in.) wide and approximately 610 mm (2 ft.) deep. We observed evidence of inadequate seismic detailing in RC structural members. Columns were reinforced with eight 25 mm diameter longitudinal bars (corresponding to a relatively high reinforcement ratio of 4.2 %); however, transverse reinforcement was in the form of 7 mm ties at 200 mm spacing. It was observed that the ties had 90-degree hooks and were not able to provide adequate confinement to longitudinal reinforcement. It was also observed that Torkari steel was used for longitudinal bars. The concrete quality was poor, as evidenced by large chunks shown in Figure 5.6b). It is possible that due to the size and detailing of RC frame components, a strong beam-weak column mechanism was formed at the ground floor level and caused the collapse.

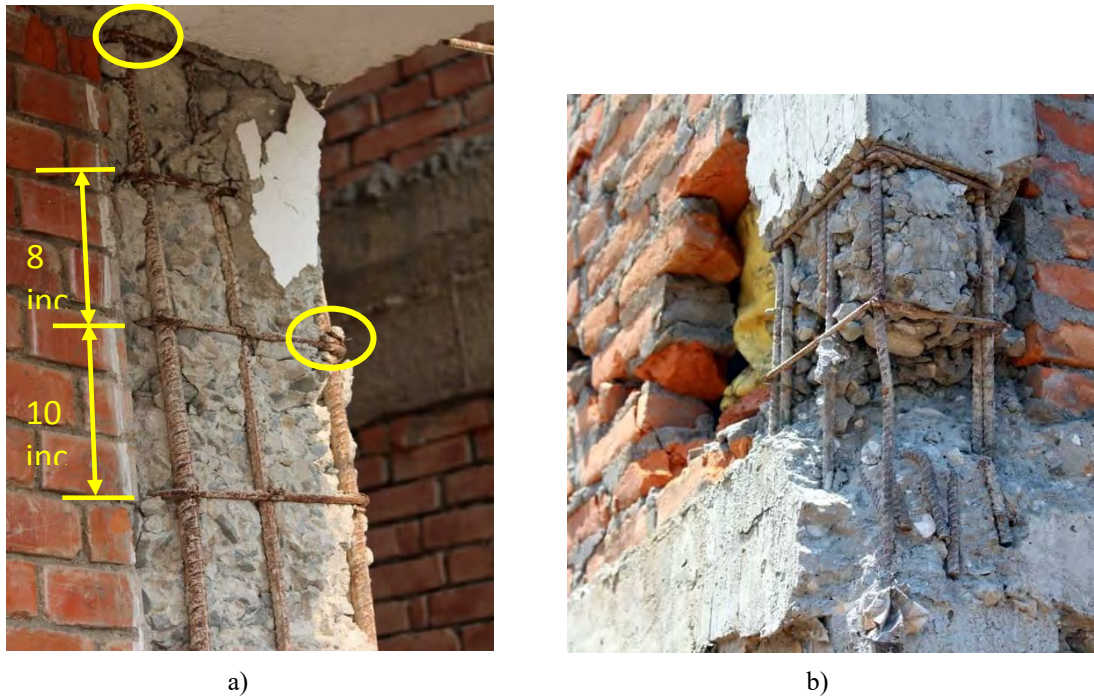

Figure 5.5: Inadequate RC construction and detailing: a) excessively wide tie spacing and 90 degree anchorage and b) lap splices provided at the floor level (Photos: Bishnu Pandey)



Figure 5.6: A collapsed 5-storey building at Khulesor, Kathmandu: a) ground floor level and b) detailing of column reinforcement (photos: Svetlana Brzev)



## 5.2.5 The effect of structural irregularities

In many instances, seismic damage was caused by structural irregularities, such as weak storey, torsional sensitivity, and setbacks. The most common irregularity observed in the affected buildings was weak storey (soft storey) irregularity, and it was usually found in mixed-use buildings with an open storefront or other commercial function at the ground-floor level. Several building collapses were attributed to increased seismic demands caused by irregularities, as illustrated in the following text.

One of the collapsed buildings, located in the Sitapaila area of Kathmandu, where several low-rise RC buildings were significantly damaged or collapsed. This five-storey building was constructed in 1999, and it was built on sloped ground. The building had a regular plan shape, with 20.3 m (66.5 ft.) length and 9.45 m (31 ft.) width, as shown on the floor plan in Figure 5.7. The building had an open ground floor which was used as a restaurant; thus, two exterior sides were open (no walls). A survey of the building ruins (Figure 5.8a) showed that RC columns were 229 mm (9 in.) square, and were reinforced with 6 longitudinal bars: 4 bars with 16 mm diameter and 2 bars with 10 mm diameter. Transverse reinforcement (ties) consisted of 5 mm wires at 203 mm (8 in.) spacing, and the anchorage was provided by 90-degree hooks. Beams were 229 mm (9 in) wide and 330 mm (13 in) deep, including slab thickness of 102 mm (4 in). Longitudinal reinforcement consisted of three 12-mm-diameter bars, while transverse reinforcement was in the form of 5-mm wires at 229 mm (7 in) centre-to-centre spacing. The cause of building collapse is believed to be a weak storey irregularity, which caused a significant seismic demand on RC components at the ground floor level. Unfortunately, these RC components were not adequately designed and detailed for seismic loading (Figure 5.8b).

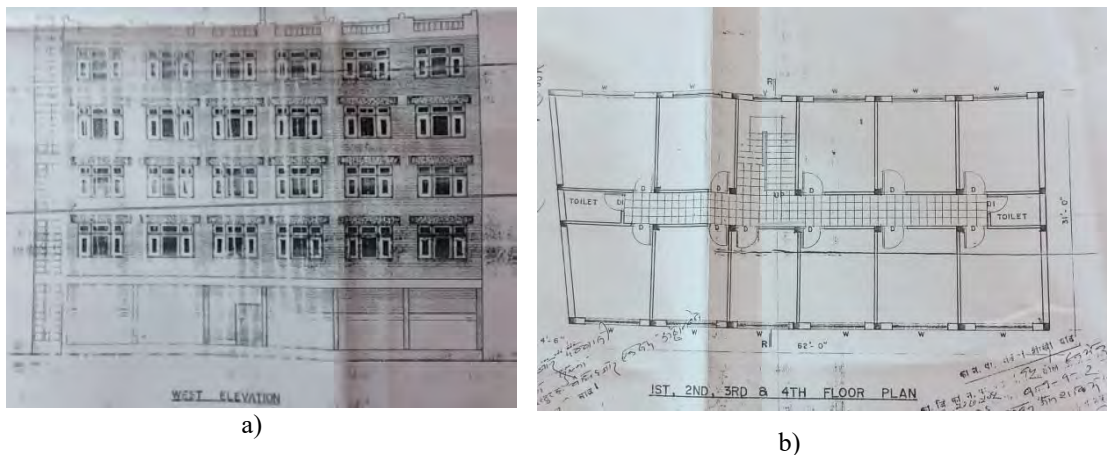

Figure 5.7: Drawings of the collapsed building in Sitapaila, Kathmandu: a) a vertical elevation, and b) a typical floor plan





a)



b)

*Figure 5.8: A collapsed RC building which had a restaurant at the ground floor level at Sitapaila, Kathmandu: a) an overall view of the building damage (note that the demolition had started at the time of the visit), and b) RC column detail (Photos: Svetlana Brzev)*

Another example of a collapsed building with a weak-storey failure mechanism was observed in the vicinity of the previous building (in Sitapaila, Kathmandu). This five-storey building had a restaurant space at the ground floor and a setback at the top floor level (Figure 5.9a). Originally standing adjacent to the neighbouring building that remained undamaged in the earthquake, when the ground floor collapsed, the building moved by more than 2 m (Figure 5.9b) and c). It was observed that the longitudinal reinforcement (made from Torkari steel) in one of the columns fractured due to significant tensile stresses at the base of the building (Figure 5.9d).



a)



b)



c)



d)

*Figure 5.9: A collapsed RC building in Sitapaila, Kathmandu: a) an exterior view of the building showing the collapsed ground floor, b) a side view showing the direction of collapse, c) a detail of the collapsed ground floor, and d) a detail of RC column failure at the base showing the fractured longitudinal reinforcement (photos: Svetlana Brzev)*

Several collapsed buildings with a weak-storey irregularity were observed in the affected regions outside the Kathmandu Valley. For example, in Charikot, the district centre for the Dolakha district, several RC buildings with open storefront collapsed, as shown in Figure 5.10. However, adjacent RC buildings in the same street and with similar construction features experienced some damage, but did not collapse (Figure 5.11). Majority of buildings in that street were hotels; thus, infill walls were continuous up the building height. It can be seen from Figure 5.11 that the masonry infill walls experienced some cracking. In some cases, these walls collapsed, but the damage in adjacent RC components was negligible.





a)



b)

Figure 5.10: Building collapses due to a weak-storey irregularity in Charikot, Dolakha District: a) an open storefront building and b) a building in the same street with the collapsed ground floor and a tower at the top (photos: Svetlana Brzev)



a)



b)

Figure 5.11: This RC building in Charikot, Dolakha District was located adjacent to the collapsed buildings shown in Figure 5.10, but it suffered only a moderate damage: a) a front elevation showing the cracks in masonry walls at the bottom two floor levels and b) a side elevation showing severely damaged/collapsed walls at the bottom two floor levels (photos: Svetlana Brzev.)

Dipjyoti School in Gongobu area of Kathmandu is another example of a building which collapsed due to an increased seismic demand caused by structural irregularities. The building was located in an area where several 5-storey high RC buildings collapsed or were severely damaged. The building was a six-storey RC frame with brick masonry infills. The building had an irregular T-shaped plan and a setback at the top floor level. Some of the infill walls were discontinuous due to an open area at the ground floor level, as shown in Figure 5.12a). It appears that the building was designed by an engineer. Typical column size was 305 mm (12 in) square, while the beams were 305 mm (12 in) wide and 432 mm (17 in) deep. It can be seen from the figure that the lowest three floors completely collapsed (Figure 5.12b). An inspection of some of the exposed columns showed closely spaced ties (including additional diamond-shaped ties), and Torkari steel used for longitudinal reinforcement (Figure 5.13). An exposed portion of the frame which did not collapse (Figure 5.14) showed absence of flexural hinging in the beams and columns (possibly because the collapse mechanism formed at the lower floors).



a)



b)

Figure 5.12: Dipjyoti School, Kathmandu: a) before the earthquake (as featured in a school brochure), and b) collapsed building after the earthquake (photos: Svetlana Brzev)





a)



b)

*Figure 5.13: Details of the collapsed Dipjyoti School in Kathmandu; note closely spaced ties and Torkari steel used for the longitudinal reinforcement (photos: Svetlana Brzev).*



*Figure 5.14: Details of a collapsed RC structure at Dipjyoti School in Kathmandu: a beam-column joint showing an absence of flexural hinging in RC beams and columns (photo: Svetlana Brzev)*

Setback at the top floor level was another common irregularity observed in the buildings throughout the affected area. This irregularity caused an increased seismic demand at the base level of the building, as illustrated on an example of a building with loadbearing brick masonry walls with a setback (Figure 5.15a). Tensile cracking developed in the pier on the left side of the building (Figure 5.15b), while the wall at the base of the building underneath the setback showed diagonal shear cracking (Figure 5.15c). It is expected that the effect of added compression due to overturning moment may have caused a decrease in shear stresses in the wall due to the interaction of shear and normal stresses.



Figure 5.15: Earthquake damage due to a setback at the top storey level: a) a building elevation showing directions of lateral seismic force and compression stresses due to earthquake-induced overturning moments, b) a masonry pier showing cracks due to flexural tensile stresses and c) a wall at the base showing shear-induced diagonal tension cracks (photos: Bishnu Pandey).

### 5.2.6 Shear or flexural failure of RC frames with infills

RC frame structures may demonstrate either flexure- or shear-dominant behavior and failure mechanisms. There are two common flexural failure mechanisms, both characterized by the development of flexural hinges in RC columns and beams. A “weak beam-strong column” flexural failure mechanism is desirable since it is associated with ductile seismic performance. It is characterized by plastic hinges which are initially formed at the beam ends, and subsequently the hinges are formed at the top and bottom of the columns at various floor levels (Figure 5.16a). This mechanism can be achieved in frames designed according to the principles of capacity design approach (Paulay and Priestley 1992), which has been adopted by most seismic codes in the world. Design and construction challenges associated with the field implementation (construction) of RC buildings designed to perform in this manner have been documented (Murty at al. 2006). An alternative flexural failure mechanism, known as “weak column-strong beam” mechanism, is characterized by flexural hinges formed only in the columns (usually at the ground-floor level of a building). This mechanism is not desirable since it may lead to a premature building collapse. Only a few low-rise RC frame buildings surveyed after the 2015 Nepal earthquake showed an indication of flexural failure. None of the surveyed buildings showed signs of plastic hinging in the beams, which is an indication of desirable weak beam-strong column collapse mechanism.

Alternatively, an RC frame with masonry infill walls can experience a shear failure mechanism, which is characterized by diagonal shear failure of masonry infill walls and adjacent RC columns. The failure occurs at the base level of a building and may lead to the ground floor collapse once the base shear capacity has been exhausted

(Figure 5.16b). This type of behaviour was most common in RC buildings damaged in the 2015 earthquake.

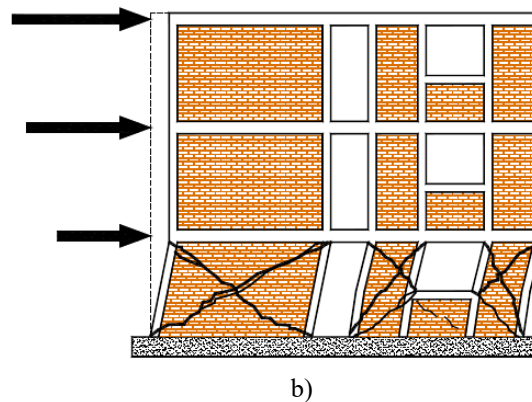
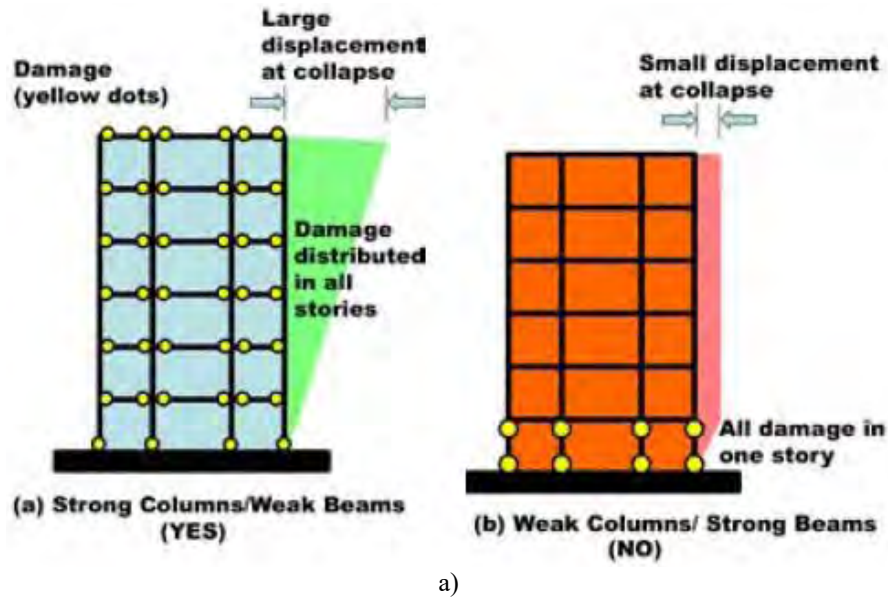

Figure 5.16: RC frame failure mechanisms: a) flexural failure mechanisms (Murty et al. 2006), and b) shear failure mechanism (Meli et al. 2011)

### 5.2.7 “Weak column-strong beam” flexural failure mechanism

The weak column-strong beam mechanism was observed in a few damaged RC buildings, and it likely caused the collapse of several other buildings. It can be illustrated in the example of a four-storey building with an open storefront in the Sitapaila area of Kathmandu shown in Figure 5.17a). Flexural hinges formed at the ground floor level, both at the base (Figure 5.17b) and at the top of a column (Figure 5.17c). It is also apparent that the detailing was deficient in that the amount of transverse reinforcement (ties) was inadequate; this caused buckling of the longitudinal reinforcement.





Figure 5.17: A building with an open storefront with the “weak column-strong beam” failure mechanism: a) a building elevation, b) a flexural hinge at the base of the column, and c) a flexural hinge at the top of the column (photos: Svetlana Brzev)

### 5.2.8 Shear-failure mechanism

It is believed that, due to the excessively small size of columns relative to the beams, it was not possible to develop a flexural failure mechanism in majority of low-rise RC buildings. Instead, a shear-failure mechanism, characterized by diagonal shear failure of masonry walls and the subsequent shear failure of RC columns, was more common in these buildings. This usually happens at the ground-floor level of a building where the seismic demand is largest. The failure occurs at the base level of a building and may lead to the ground floor collapse once the base shear capacity has been exhausted.

The capacity of an RC frame that experiences a shear failure mechanism is largely governed by the masonry wall capacity. Essentially, the behaviour is similar to masonry shear walls in confined masonry construction, where masonry walls are enclosed by RC confining elements (tie-columns and tie-beams). Confined masonry is a load-bearing wall system and the effects of lateral seismic loads are resisted by composite action of masonry walls and RC confining elements. A backbone curve for a confined masonry wall is shown in Figure 5.18 (Meli, et al. 2011). The figure illustrates a shear-dominant behaviour of a confined masonry wall subjected to lateral seismic load and presents a conceptual force-deformation curve (backbone curve). There are two critical stages in the behaviour of a confined masonry wall with a shear-dominant behaviour: a) an onset of cracking in the masonry (point 1 on the diagram), and b) the maximum capacity (point 2). The maximum capacity is characterized by extensive diagonal cracking in the masonry wall that extends into the adjacent RC tie-columns. It is expected that the lateral load-resisting capacity will drop after point 2, although the structure will still be able to sustain lateral and gravity loads; this is accompanied by increasing lateral drift and damage.



A detailed survey of 98 RC low-rise buildings with masonry infills was performed after the 2015 Gorkha earthquake. One of the objectives of the survey is to correlate the amount of walls (wall index) with the damage grade in RC buildings. The results have shown a strong correlation between the wall index and the damage grade, indicating a predominant shear failure mechanism in these buildings (Brzev et al., 2017).

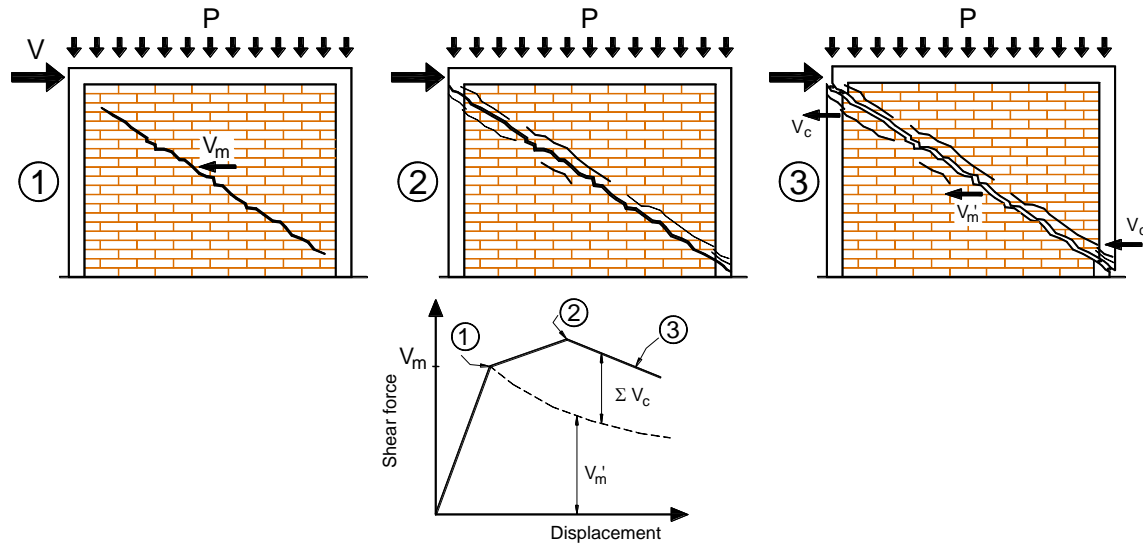

Figure 5.18: Failure mechanism in composite RC and masonry wall system with shear-dominant behavior is similar to confined masonry (Meli, et al. 2011).

This mechanism is illustrated in the example of a six-storey building in the Gongobu area of Kathmandu that experienced heavy damage at the ground-floor level (Figure 5.19a). Shear failure was observed in several walls at the ground-floor level, and the cracking extended into the adjacent RC columns (Figure 5.19b). It was observed that the quality of RC construction was poor, and reinforcement detailing deficiencies were also observed in this building. A few other examples of this behavior are illustrated in Figure 5.20. In some cases, a separation of infill wall from the frame has occurred.



*Figure 5.19: Shear failure of a RC frame building with masonry infills in the Gongobu area of Kathmandu: a) an exterior view of the building in longitudinal direction, b) an interior transverse wall showing in-plane diagonal shear failure of masonry walls, and c) diagonal cracks extended into the RC columns (photos: Svetlana Brzev)*



*Figure 5.20: Examples of RC frame and wall interaction: a) a vertical separation crack between wall and the RC column and a diagonal shear crack extending from the wall into the column and b) in-plane shear cracking of the wall extended into adjacent RC columns (photos: Bishnu Pandey)*

### ***5.3 Medium-Rise Reinforced Concrete Buildings***

A 15-storey residential building complex in Dhapasi area, Kathmandu was significantly damaged in the earthquake (see Figure 5.21). The complex was located on the top of a hill with very attractive views. To maximize the view potential, the buildings had many adjoining residential units in the direction facing the view; this created a long and narrow building floor plan. There were over 300 relatively upscale residential units in the complex. Hundreds of people have lost their homes due to the earthquake, and it is believed that the property loss is several millions of dollars. It appears that it would be difficult to reoccupy the buildings without an extensive retrofit.

It was observed during the field survey that the buildings had suffered extensive damage. There was extensive dislodging of the exterior brick infills from the RC structure (see Figure 5.22). We were not able to access the interior of these buildings and assess the damage. We did not have access to structural drawings for the buildings. However, it appears that these buildings were designed with RC moment frames as the primary structure, and were infilled with brick masonry walls to complete the architectural and building functional requirements.

In general, RC moment frames are flexible laterally thus lateral movements due to earthquake loading can be significant. Brick infill walls adjacent to the RC moment frames are rigid and brittle. Any significant lateral movements in the frame are expected to cause cracking in the brick infill walls. We observed significant damage in the masonry infill walls, which was likely caused by excessive lateral deflection in the RC moment frames. In many cases, the entire sections of masonry walls fell out.

These buildings would have not suffered extensive cracking or damage due to excessive lateral movements had the seismic resisting system been a much more rigid system, such as a system of RC shear wall system with ductile detailing. Shear walls are the main elements in the building resisting lateral seismic loads. If these buildings had RC shear walls, they would be unlikely to exhibit the type of damage we observed.

It should be noted that medium-rise residential buildings, ten-to-twenty storeys high, are very common in high seismic regions of North America. When designed and constructed properly, these buildings are expected to continue to serve the building occupants after a moderate earthquake.



Figure 5.21: Medium-rise RC apartment building complex that experienced damage in the earthquake (photo: Svetlana Brzev)



a)



b)

Figure 5.22: Damage patterns in medium-rise RC buildings: a) extensive diagonal cracking in masonry infills indicates a significant drift, and b) some of the unconfined masonry walls fell off the building (photos: Svetlana Brzev).



## 5.4 Summary

Many low-rise RC buildings in the Kathmandu Valley and smaller towns within the affected districts were exposed to the 2015 Gorkha earthquake. It was observed that RC buildings suffered severe damage at some localities (pockets) in Kathmandu, while similar RC buildings remained undamaged at other localities. This can be explained by the higher shaking intensity of earthquake shaking at some locations, although the few available records indicate low ground accelerations in Kathmandu. In general, low-rise RC buildings in Nepal are either non-engineered (constructed by masons or petty contractors without input of qualified engineers) or pre-engineered, that is, designed in accordance to the Mandatory Rules of Thumb (MRT) (NBC 201:1994). The most significant damage was observed to the buildings with an open ground floor, which were mostly buildings with mixed-function with commercial ground floor (housing a restaurant or stores). Some of these buildings experienced a total collapse due to the weak storey effect. Due to the absence of ductile detailing, the damage was mainly concentrated in the columns and masonry infill walls. Similar observations were made for the buildings on sloped sites in hill towns where irregularities were created due to bottom storey columns which had unequal lengths to match topographic conditions of the slope. It is believed that the 2015 Gorkha earthquake, characterized by low shaking intensity, acted as a test for these RC buildings and provided a warning regarding possible consequences in the form of severe damage and/or collapse in a more severe future earthquake which is expected in Nepal.

Medium-rise RC buildings were designed without sufficient considerations for drift control and torsion. Excessive lateral building movements have caused extensive damage to entire buildings to the point such that repair was not economically feasible.

## 5.5 References

Brzev, S., Pandey, B., Maharjan, D.K., Ventura, C. (2017) Seismic vulnerability index for low rise composite reinforced concrete and masonry buildings in Nepal, Paper No. 3522, Proceedings of 16<sup>th</sup> World Conference on Earthquake Engineering, Santiago, Chile.

JICA (2002). The Study on Earthquake Disaster Mitigation in the Kathmandu Valley, The Final Report, Japan International Cooperation Agency, Tokyo, Japan.

NBC (1994). NBC 201-1994 Mandatory Rules of Thumb – Reinforced Concrete Buildings with Masonry Infill, Nepal National Building Code, Department of Urban Development and Building Construction, Kathmandu, Nepal.

NBC (1994). NBC 105-1994 Seismic Design of Buildings in Nepal, Nepal National Building Code, Department of Urban Development and Building Construction, Kathmandu, Nepal.

Meli, R., Brzev, S. et al. (2011). Seismic Design Guide for Low-Rise Confined Masonry Buildings. Earthquake Engineering Research Institute, Oakland, California ([www.confinedmasonry.org](http://www.confinedmasonry.org)).

Murty, C.V.R, Brzev, S., Faison, H., Comartin, C.D., and Irfanoglu, A. (2006). At Risk: The Seismic Performance of Reinforced Concrete Frame Buildings with Masonry Infills. World Housing Encyclopedia, Earthquake Engineering Research Institute, Oakland, California, U.S.A., Publication WHE-2006-03, 70 pp. ([www.world-housing.net/tutorials/reinforced-concrete-frames-tutorials](http://www.world-housing.net/tutorials/reinforced-concrete-frames-tutorials))

Paulay, T. and Priestley, M.J.N. (1992). Seismic Design of Concrete and Masonry Buildings, John Wiley and Sons, Inc., New York, USA, pp.744.

## 6 Rural Housing: Performance of Vernacular Stone Masonry Buildings

Bishnu Pandey<sup>1</sup> and Svetlana Brzev<sup>2</sup>

### 6.1 Background

The 2015 Gorkha earthquake inflicted heavy damage on housing in the mountainous rural areas of central and western Nepal. In several districts, including Gorkha, Dhading, Nuwakot, Sindhupalchowk, Kavrepalanchowk and Dolakha, over 50,000 rural houses experienced severe damage or collapse. These houses are typically one- to three-storeys high with floor height of about 2.4 m, as shown in Figure 6.1. The houses have regular, usually rectangular, plan shape. A typical house has three or four rooms, and a typical room dimensions are 3.5 m by 3 m. Most houses have 50 to 60 cm thick stone walls with mud mortar, with exterior stone masonry wythes and with rubble in the middle; this type of construction is known as random rubble stone masonry construction (Figure 6.2). The floors have wooden joists that run parallel to the building width (Figure 6.3), and are covered either by wooden planks or bamboo mats that run across the joists that support clay toppings. Most buildings have pitched roofs, which are made of wooden purlins and rafters. In many traditional buildings, there is an overhang provided by extended rafters, which are connected to the supporting wall through brackets (Figure 6.4a). Roofing is either light-weight material such as metal (CGI) sheets (Figure 6.4b) or thatch; however, in some cases heavy stone (slate) tiles are placed over small timber logs that serve as rafters and purlins. There were a few reinforced concrete (RC) frame buildings, mostly located along major highways that connect district headquarters and other major towns. These buildings have infills made of stone, bricks or concrete blocks and have experienced similar earthquake damage to the urban RC construction that is described elsewhere in the report.

---

<sup>1</sup> British Columbia Institute of Technology (BCIT), Vancouver, BC, Canada

<sup>2</sup> British Columbia Institute of Technology (BCIT), Vancouver, BC, Canada



a)



b)

Figure 6.1: Typical rural stone masonry houses: a) a single-storey house and b) a three-storey house (Photos: S. Brzev)



a)



b)

Figure 6.2: Typical stone masonry walls: a) exterior view and b) vertical section through a multi-wythe wall (Photos: S. Brzev)





Figure 6.3: Floor structure in stone masonry houses: a) exterior view and b) interior view (Photos: S. Brzev)



Figure 6.4: Typical roofs: a) traditional wooden roof and b) CGI sheet roof (Photos: S. Brzev)

## 6.2 General Damage Observations

The observed damage to rural stone masonry houses ranged from minor damage (e.g. cracks at the corners of window and door openings) to complete collapse. Figure 6.5 shows a bird's-eye view of a village in the Sindhupalchowk District where most stone masonry houses were either severely damaged or collapsed. Typical damage patterns included delamination of thick stone walls; partial or complete out-of-plane collapse of walls, including gable walls; diagonal cracking in the piers between the openings; vertical cracks at the wall corners and collapse of upper storeys in the two- or three-storey houses. It is interesting to note that some houses in the same village experienced only minor cracking while large majority of houses completely collapsed.



*Figure 6.5: Extensive damage to rural stone masonry houses, Sindhupalchowk District (Photo: B. Pandey)*

Ground motion records of the earthquake were not available for the rural areas; however, it was inferred from the observations that the ground shaking was not significant. In the Dolakha Bazaar, a market which is less than 5 km away from the epicentre of the May 12, 2015 aftershock ( $M_w$  7.3), RC buildings located in the same neighbourhood as the damaged stone masonry houses remained undamaged in the earthquake. Stone buildings shown in Figure 6.6a were located within 50 m from undamaged non-ductile RC buildings shown in Figures 6.6b and 6.6c. The observations and discussion in the following sections may not apply in situations where the ground motion is severe.





a) Extensive damage/collapse of stone masonry houses



b) No visible damage to non-ductile RC frame with infill adjacent to a heavily damaged stone masonry house



c) No damage observed in the concrete building next to damaged stone houses.

*Figure 6.6: A comparison of earthquake performance for stone masonry and adjacent RC houses, Dolakha District (Photos: B. Pandey)*

### 6.3 *Delamination of thick stone walls*

Delamination (bulging) was observed in thick multi-wythe stone walls, as shown in Figure 6.7a. This damage pattern is typical for thick random-rubble stone masonry walls in which it is not possible to provide through-stones (headers), as shown in Figure 6.7b. This was mostly observed in the districts of Rasuwa and Sindhupalchowk, where the size of stones was small compared to the Dolakha District. Multi-wythe walls had only two exterior wythes with small pebbles or just clay in the middle; thus, there was no interlocking action of stones.



Figure 6.7: Delamination of stone masonry walls: a) an example of delamination, and b) through-stones provided in this wall are effective in preventing delamination (Photo: B. Pandey).

### 6.4 *In-plane shear failure of masonry piers*

In-plane shear cracking was observed in some stone masonry piers, particularly in the buildings where wall resistance was enough to cause out-of-plane failure. Inclined shear cracks originating from the corners of openings extended across the masonry piers. Figure 6.8 shows a house with extensive shear cracking in the walls. The walls were of random-rubble stone construction in mud mortar but had cement mortar pointing at the façade.





Figure 6.8: In-plane shear cracks in stone masonry walls (Photo: S. Brzev)

### 6.5 Out-of-plane wall failure

Out-of-plane failure of stone masonry walls was commonly observed after the earthquake. In particular, gable walls collapsed at the roof level in most stone masonry houses in the earthquake-affected region. The failure of gable walls was observed even in buildings which otherwise performed well, as shown in Figure 6.9a. Out-of-plane failure was not only limited to gable walls. In areas heavily affected by the earthquake, stone masonry walls toppled outwards due to the absence of horizontal bands or floor joists that confined the walls (see Figure 6.9b).



Figure 6.9: Out-of-plane failure wall collapse: a) collapse of a gable wall in an otherwise undamaged building and b) complete collapse of a transverse wall (Photos: B. Pandey)



a) Complete failure of side wall



b) A partial failure of gable wall



c) Failure of gable wall extended



d) Failure of gable wall

Figure 6.10: Patterns of out-of-plane failure in stone masonry houses (Photos: B. Pandey)

In partially damaged buildings, it was observed that out-of-plane failure was most prevalent in gable walls laid along the building's shorter plan dimension. A possible reason for poor performance of gable walls is due to the fact that the timber roof structure (consisting of joists and planks) is not supported by the gable walls – it is supported by longitudinal walls. In the construction practice, joists are normal to face walls. The other walls bear only planks, which are small in size and partially bear on the walls. As a result, gable walls act as free-standing cantilevers which are vulnerable to out-of-plane vibrations. Figure 6.10b shows a typical building that has longitudinal exterior walls which remained undamaged while the gable walls collapsed. Figure 6.9b also illustrates this observation.

### 6.6 Roof-to-wall and floor-to-wall connections (wall bearing)

In several cases, building collapse was initiated by the roof and/or floor collapse. It is believed that one of the causes of collapse was partial bearing of wooden floor joists on the supporting walls. During the earthquake, some of these joists moved away from the walls and caused the floors to cave in; this led to the subsequent building collapse. This failure mode was prevalent in two- and three-storey buildings where the floor structure was held in place through compression stresses imposed by the upper storey walls. Figure 6.11a shows floor joists on the verge of slipping off the wall, which is a sign of impending collapse. Figure 6.11b shows the other side of the wall where recent mud



painting of joists indicates that the relative movement is about 8 cm. Figure 6.12 shows the joists supported by the wall over full length. It was evident that the floor joists restrained inner wythes of random-rubble stone masonry walls while the outer wythes collapsed in some cases due to the partial joist bearing (Figure 6.12).



a) Floor joist about to slide off the wall

b) Mark in the joists indicating relative displacement between floor and walls

Figure 6.11: Floor joists about to slide off the wall, Sindhupalchowk District (Photos: B. Pandey)



a)

b)

Figure 6.12: Partial bearing of floor joists on a stone masonry wall: a) a view from the top and b) floor joists on top of the wall prevented collapse of the interior wall wythe (Photos: B. Pandey).

In some areas (e.g. Dolakha District), floor joists in many buildings extended over the full wall thickness, often over bearing logs running parallel to supporting walls; this resulted in comparatively better earthquake performance. Figure 6.13 shows a building with closely spaced joists at both floor levels. Although the building sustained heavy damage at the roof level, it is believed that the joists were effective in preventing the wall collapse.



*Figure 6.13: A building with floor joists bearing over the entire wall thickness (Photo: B. Pandey)*

Floor joists bearing over the full wall thickness were also observed in two-storey buildings with porches or balconies, houses that performed well in the earthquake. In the village of Kalikasthan, Rasuwa District, two-storey stone masonry houses sustained the earthquake without collapse (but with heavy damage), while most single-storey houses in the same village were flattened to the ground. A careful observation of housing construction practices in the village showed that the villagers did not make fully bearing floor joists over a wall. However, at first floor level of two-storey houses, they usually have balconies that have extended joists passed over the wall. Because of the balconies or porches, the joists had to fully bear on exterior walls and extend outside the building. As a result, two-storey buildings experienced damage or collapse at the upper floors, but the ground floors remained functional after the earthquake. Figure 6.14a shows a building where the second storey collapsed in the earthquake but the ground floor remained intact due to the front porch. Figure 6.14b shows a portion of the building which survived the earthquake without significant damage; this could be attributed to the presence of a balcony.





Figure 6.14: Good seismic performance of two-storey stone masonry houses: a) ground floor of a two-storey house with a porch and b) a two-storey house with a balcony (Kalikasthan village, Rasuwa District) (Photos: B. Pandey)

### 6.7 The effect of horizontal bands

In some cases it was observed that stone masonry walls are confined either by the floor structure or wooden bands provided at the perimeter of the building at each floor level (Figures 6.15a) and b). Two- and three-storey stone masonry buildings with bands performed well in the earthquake. Figures 6.16c) and d) show buildings in the area where stone masonry buildings experienced severe damage; however, the buildings shown in the picture remained undamaged. This can be explained by the presence of a timber band at the floor levels. Buildings with floor joists running in both directions with full bearing on the walls also performed well in the earthquake, as discussed earlier in this section. However, buildings without the timber bands experienced damage ranging from vertical cracks at the wall intersections (see Figure 6.16) to complete wall collapse.



a) Details of timber bands

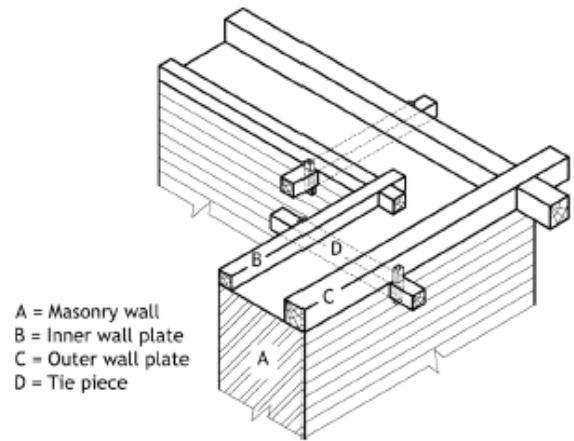

b) Timber band (a conceptual drawing)  
(Shankya et al., 2014)



c) A stone masonry house with a large number of windows remained undamaged due to the presence of floor bands (Bhimsen).



d) A four-storey stone masonry house with floor bands remained undamaged in the earthquake (Dolakha District).

*Figure 6.15: Timber bands in stone masonry houses (Photos: B. Pandey)*





*Figure 6.16: Vertical cracks in a building without timber bands (Photo: S. Brzev)*

Stone masonry houses with rigid floors such as RC slabs performed well in the earthquake. Rigid RC slabs have a positive effect since they are cast on top of the walls and help maintain structural integrity of a building. For example, a four-storey house in Dolakha Bazaar had stone masonry walls and an RC floor slab, as shown in Figure 6.17 (shown in the background). The house did not experience damage at the bottom three storeys with RC slabs, but the top floor with the light-weight CGI sheet roofing collapsed. Several adjacent stone masonry houses that did not have RC floors collapsed in the earthquake.



*Figure 6.17: A positive effect of RC floor slabs in a stone masonry house (Photo: B. Pandey)*

## ***6.8 Performance of stone masonry buildings with seismic provisions***

Most stone masonry buildings in rural areas of Nepal are non-engineered buildings constructed in a traditional manner without input of qualified technicians. However, the Nepal Building Code issued guidelines for non-engineered masonry buildings (NBC 203:1994), guidelines that contain a few seismic provisions for non-engineered stone masonry buildings. The key seismic provisions are: i) horizontal seismic bands at the plinth, lintel and roof levels (made of timber or RC) and ii) provision of a single vertical reinforcing bar at the wall intersections and jambs (openings). The use of cement mortar is recommended for construction of stone masonry walls. The CAEE team has not seen any examples of application of NBC 203 provisions in houses, although it is possible that some undamaged houses were constructed with seismic provisions. However, the team visited a school complex in the village of Sangachok, Sindupalchowk District. The village was severely affected by the earthquake, with 167 deaths out of the total population of 3,000. Many stone masonry houses suffered severe damage or collapse. The school complex was located on the top of a hill. The classrooms were housed in two RC frame buildings with masonry infills – one of these buildings collapsed at the ground-floor level and the other was severely damaged. A single-storey school addition built in stone masonry with steel truss roof and CGI sheet roofing collapsed in the earthquake (see Figure 6.18a). A few NBC 203 seismic provisions were observed, such as continuous RC lintel band with 4 longitudinal reinforcing bars (Figures 6.18b and c), and vertical reinforcing bars provided at the wall intersections (Figure 6.18d). The walls were about 50 cm thick and were built using mud mortar. The building was located on the top of a steep slope (Figure 6.19a), and it is expected that the topography influenced the intensity of shaking and seismic performance. It should be noted that the building was also built with pilasters, which might have prevented the collapse of the walls at the rear side of the building (top of the slope) (Figure 6.19 b).





a)

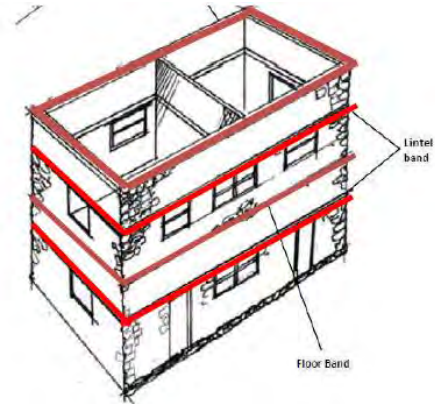

b)



c)



d)

Figure 6.18: Damage of a stone masonry school located in the village of Sangachok , Sindupalchowk District (Photos: S. Brzev)



a)



b)

Figure 6.19: Stone masonry school building in the village of Sangachok, Sindupalchowk District: a) topography (slope at the rear side) and b) a view of the rear wall showing the pilasters (Photos: S. Brzev)

## ***6.9 Improving earthquake safety of stone masonry for post-earthquake reconstruction***

Stone is a primary material for housing construction in the mountainous regions of Nepal. In many rural communities, there is no viable alternative to stone as a construction material due to the challenges associated with the production and transportation of man-made materials such as bricks, cement and steel. Based on the observations during the reconnaissance mission, it was found that proper construction techniques will significantly reduce the risk of collapse of a stone masonry house even without the use of steel and cement. The following recommendations can be followed for enhancing earthquake safety of stone masonry houses:

1. Provide continuous timber bands at all sill, lintel and floor levels.
2. Avoid stone masonry gable walls. Build a stone masonry wall up to the eaves level (roof timber band level), and construct a gable using light-weight panels such as bamboo mats or thin wooden planks that are attached to the roof.
3. Provide floor joists that fully bear on walls in both horizontal directions. Ensure anchorage of these joists to the walls wherever possible.
4. Use stones of proper shape and size. Provide through-stones at regular intervals in random-rubble stone masonry walls.

Note that the National Building Code of Nepal contains a guideline for improving earthquake safety of stone masonry construction (NBC 203:1994). The authors of this report have also developed a simple illustrated guideline for improved stone masonry construction for use in Nepal (Pandey, Brzev, Culbert, and Schoenfeld, 2017).

Stone masonry houses in severely affected areas constructed with timber bands and joists that fully bear on the walls performed well in the earthquake. Some owners constructed new houses with timber bands after the earthquake (see Figure 6.20a). The CAEE team also observed a class in mason training undertaken after the earthquake, a very important education initiative to ensure safe stone masonry construction (Figure 6.20b).





Figure 6.20: Reconstruction of stone masonry houses: a) a newly constructed stone masonry house with floor bands and corner stones and b) mason training program after the earthquake (Photos: B. Pandey and S. Brzev)

Since collapse of stone masonry walls in mud mortar is a major concern related to seismic safety of these buildings, a suitable technology that maintains the wall integrity while keeping the traditional construction materials is of critical importance. For example, gabion wire (galvanized steel wire mesh) could be considered for application to stone masonry walls to enhance their safety against effects of lateral earthquake loading. Figure 6.21 shows an application of gabion wire for 30-year-old retaining stone walls along the roadside in an earthquake-affected area of Nepal, confirming its durability and effectiveness.



Figure 6.21: Gabion wire: a) a 30-year old application in 30-year old retaining walls in Nepal and b) a detail of the wire mesh (Photo: B. Pandey)



## 6.10 Summary

Rural stone masonry houses experienced the most significant damage due to the 2015 Gorkha earthquake. Most fatalities in this earthquake were attributed to the collapse of stone masonry housing. Several earthquake damage patterns were observed in these buildings, including delamination of thick stone masonry walls in mud mortar, collapse of floors and roofs due to excessive movement of joists away from the walls, separation of orthogonal walls, falling off of gables and out-of-plane walls, and wide localized cracks in the walls. Some buildings with wooden bands at floor level showed a significantly better performance in the earthquake. Walls built using stones of relatively regular shape and with through-stones also experienced less damage. Use of gabion wire which is currently used in the construction of retaining walls on the roads, shows some prospects. There is a potential for using similar construction schemes for stone walls in housing to enhance their resistance against stones falling off during earthquake shaking.

## 6.11 References

Bothara, J. and Brzev, S. (2011). A Tutorial: Improving the Seismic Performance of Stone Masonry Buildings. Earthquake Engineering Research Institute, Oakland, California, U.S.A., Publication WHE-2011-01 ([www.world-housing.net/tutorials/stone-tutorials](http://www.world-housing.net/tutorials/stone-tutorials)).

NBC 203: 1994. *Guidelines for Earthquake Resistant Building Construction: Low Strength Masonry*, Ministry of Physical Planning and Works, Department of Urban Development and Building Construction, Kathmandu, Nepal.

Pandey, B., Brzev, S., Culbert, R. and Schoenfeld, G. (2017). *Illustrated Guidelines for Construction of Stone Masonry Houses in Seismic Regions of Nepal*. British Columbia Institute of Technology and Builders Without Borders, Vancouver, Canada.

Shakya, M., Varum, H., Vicente, R. and Costa, A. (2014). Seismic Sensitivity Analysis of the Common Structural Components of Nepalese Pagoda Temples, *Bulletin of Earthquake Engineering*, Vol. 12, p. 1679–1703.

## 7 Performance of School Buildings

**Bishnu Pandey<sup>1</sup>**

### 7.1 Introduction

When the M7.8 Gorkha Earthquake struck Nepal, 14 districts across its Western and Central regions experienced intense shaking. It was found that the impacts of the earthquake were more pronounced in the education sector. A total of 8,242 public schools were damaged in the earthquake with estimated losses of US\$313 million in the education sector alone (Nepal Sector Reports, 2015). The earthquake interrupted the education of approximately one million children.

The CAEE team visited several school sites in affected regions both inside and outside the Kathmandu valley. In each school site visited, visual assessments of schools were made. In some schools, a more detailed survey was also conducted to learn the impact of school retrofits carried out over the last 15 years by the government of Nepal and non-governmental organizations, including the National Society for Earthquake Technology- Nepal (NSET). The effects of the earthquake on Nepal's educational infrastructure offers a rare opportunity to study whether previous interventions have resulted in safer schools. The detailed survey included visual assessments accompanied by interviews of technical professionals involved in school construction and school management, as well as parents. This article presents the overall performance of school facilities in the affected region where the CAEE team visited. Also discussed is the performance of purportedly disaster-resistant public school buildings, whether retrofitted or newly constructed, against typical public school buildings.

### 7.2 Vulnerability of School Buildings and Seismic Upgrading in Nepal

The stock of school buildings in Nepal was mostly unreinforced masonry using stone or brick. In hilly regions of the country, the material primarily used for school construction is random rubble stone with mud mortar. No reinforcement is used in the construction of walls. Timber is used for floor or roof construction. Schools in and around urban centres are made of brick walls, in some cases confined by non-ductile reinforced concrete beams and columns. Traditional artisans build almost all of these schools without any inputs from an engineer. The major problem of the buildings was lack of connection between different components (Bothara et al, 2004). Orthogonal walls were not structurally connected, flexible floors were constructed of timber planks or bamboo strips simply supported on timber joists. These joists were not tied up to the

---

<sup>1</sup> British Columbia Institute of Technology (BCIT), Vancouver, BC, Canada

walls. Roofs made of CGI sheets on timber battens were not firmly connected to walls. Gable walls were not tied to roof structures. Hence, buildings were most resembled stacked material without interconnection. They were susceptible to losing integrity even in small shaking. When floors and roofs are flexible, the orthogonal walls do not provide stability in lateral shaking. The unreinforced walls may fail out-of-plane, and also in-plane damage is expected because the structures don't have enough shear- and flexural-tension resistance.

Recently, the Government of Nepal launched a program to retrofit public school buildings in Kathmandu Valley. Started in 2012, the government's program got set into motion after a strong campaign culminating a decade of efforts made by the nation's engineering community. The very first school was seismically upgraded by NSET in 1999 after an assessment that showed 60% of school buildings needed immediate intervention as they were built by traditional material such as adobe, stone rubble in mud mortar, or brick in mud mortar (Dixit and Pandey, 2003). Since then, about 40 schools were retrofitted, mostly through the initiative of NSET. Since then, the government started a major program aiming to retrofit about 300 additional schools in the valley.

The seismic upgrade of school buildings in Nepal focused mostly on unreinforced masonry wall buildings. Because of the inherent weakness of the URM school buildings and taking into account the socio-economic condition of the society of the developing country, any strategy of seismic intervention to those buildings should have considered affordability along with safety. The need was for a simple and cost-effective seismic upgrade with use of local material, avoiding any complex construction system. NSET started seismic upgrade of URM school buildings with selective reinforcement in splint and bandage along with stitching of orthogonal walls. The focus was to enhance the integrity of the building. The connections between orthogonal walls were improved by continuous reinforced micro-concrete strips in the corners and T- junctions. The vertical continuous strips, called splints, were provided from foundation to roof level. Similarly, horizontal strips, called bandages were provided to run horizontally around all the walls on both side of the walls. The splints and bandage were 50-mm-thick reinforced micro-concrete sections applied on bare walls after racking mortar from the brick work joints. The two faces of the bandages were connected using staggered dowel bars. The bandages were provided at sill and lintel levels. Figure 7.1 shows a typical construction of splint and bandage.



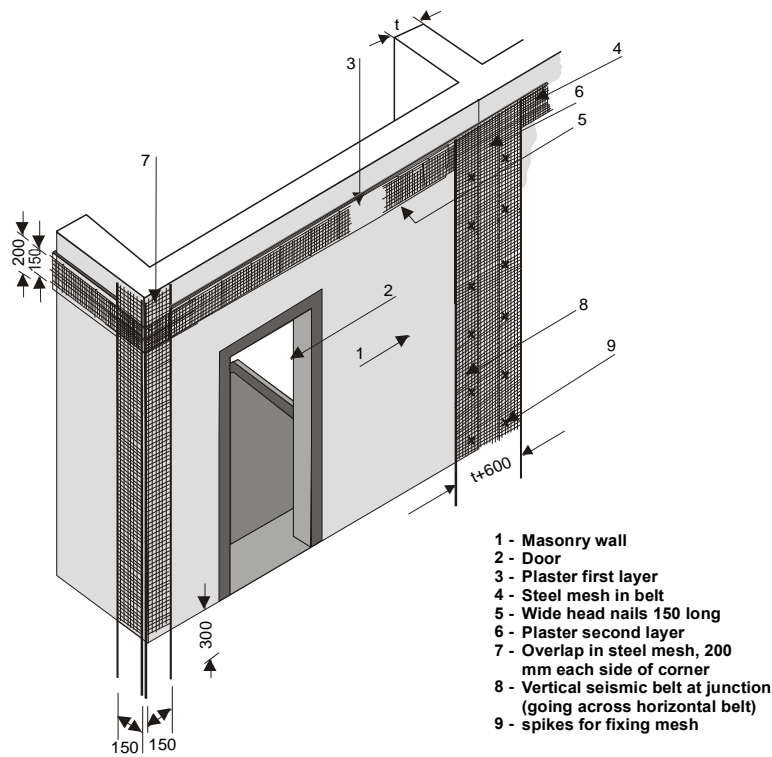

Figure 7.1: Splint and bandage technique of retrofitting of unreinforced masonry wall (Bothara et al, 2002)

Figure 7.2 shows the actual construction process in Bhuvaneshowri School, Bhaktapur, the first retrofitted school in Nepal. The timber floors were replaced by a thin concrete slab to make the rigid diaphragm. The roof battens were braced and tied to the walls at the roof band. Gable walls were also reinforced and anchored to the roof system. This system of seismic upgrading is typically applied in URM school buildings. In some schools the micro concrete cover is applied over the entire wall in the form of jacketing.

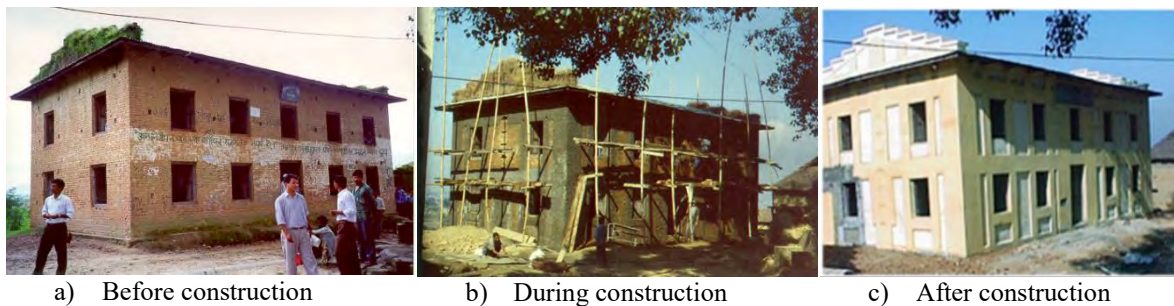

Figure 7.2: Application of splint and bandage technique of seismic retrofit in URM school building in Nepal

New construction with earthquake-resistant elements in the masonry construction includes reinforcement in seismic bands at lintel and floor levels. These new constructions typically include reinforced concrete floors.

### ***7.3 Performance of Conventional School Buildings Compared to Residential Houses***

It was evident from the government figures of earthquake losses in various sectors that the education sector was the hardest hit, and damage in school buildings was hence expected to be higher than that in other infrastructure or built environments. We confirmed this by the observation in the field. In the rural areas of Rasuwa and Sindhupalchowk, it was evident that performance of school buildings was poorer than that of residential houses in many communities. Figure 7.3 illustrates a case in Kadambas village in Sindhupalchowk, where a two-storey school building built with stone masonry walls and concrete slab floor had the roof collapse, leaving no air pocket space in between. If the earthquake had occurred during class time, several hundreds of children would have been under the piles of floor and roofs stacked onto each other. The school building, visibly massive when looking at the slab and walls, was lacking all necessary earthquake-resistant features. A typical class room was 5 m by 6 m in size bounded by unreinforced stone masonry walls 3 m in height and 60 cm in thickness. The floor and roof slabs were 150 mm thick, made of minimally reinforced concrete. A simple base shear check shows that the unreinforced walls were not able to bear the shear generated by the significant mass of the walls and floors, even up to acceleration of 0.1 g, which was most likely well exceeded during the main shock of the event.

This was in contrast to the damage observed in most of residential houses in the village, where a majority of them were single-storey buildings with light thatch or CGI sheet roofs. Although many of the residential houses sustained damages, very few of them completely collapsed as did the school building. The major factor for this was not necessarily that these village houses had any significant features that resist lateral shaking from earthquakes, but their dimensions and wall, floor and roof masses were not so critical as to trigger significant base shear for the earthquake event. Figure 7.3b) shows a panoramic view of the village next to the school. Most of the houses were observed to be in repairable condition, although many villagers were so afraid of cracks in the walls that they left their houses for temporary shelters. This observation of disproportionate damage of schools was observed in other villages of Sindhupalchowk and in other districts hit by the earthquake. The absence of earthquake considerations bring higher consequences in schools as the buildings are bigger and the population exposure is greater.



a. Kalidevi Secondary School building in Kadambas, Sindhupalchowk

a) Village community within 100m of the Kalidevi school, Kadambas, Sindhupalchowk

*Figure 7.3: School buildings are disproportionately damaged in comparison to residential houses*

#### **7.4 Performance of School Buildings with Seismic Upgrades**

School buildings that were said to be designed or retrofitted for earthquake safety generally performed better than other buildings-- but not always. In the moderate intensity shaking of the Kathmandu Valley, the retrofitted and earthquake-safe schools observed were completely undamaged, even while other school buildings at or near the school experienced minor or moderate damage. In the heavier shaking of Rasuwa and Sindhupalchowk Districts, school building performance was most variable. Only some of the supposedly safer schools performed better than similar school buildings nearby.

While retrofitted schools in Kathmandu and Bhaktapur were generally undamaged, we found several lapses in design or construction at one of the Kathmandu retrofits during our detailed visual assessment. At the base of the walls, the masons had created a stitch band beam. However, where the band was discontinuous on one side of the block; vertical bars came down and poked out of the bottom (Figure 7.4). While this school performed well in this earthquake, retrofit design and construction flaws may lead to unnecessary damage in larger events. In the left photo, vertical bars poke out the bottom of a retrofit band. A horizontal retrofit band at the bottom of the wall is missing on this side of the building. On the roof top, the vertical bars are secured by only small patches of concrete, partially covered in the photo by discarded school benches. The masonry columns supporting the roof overhang were not strengthened in any way and remain unsupported below the balcony overhang. On the roof, vertical bars continued up through the ceiling slab and were bent over only a short distance. The ends of the vertical band bars were covered with a small 16-inch patch, leaving only 8 inches for bars to be bent in each direction. The distance was too small to allow the bars to develop their full strength during an earthquake. In a stronger earthquake, the bars would have popped through the small roof batch.





*Figure 7.4: Several design and construction flaws observed in a recently upgraded school building in Kathmandu*

More globally, the retrofit addressed the masonry walls of the school only. The retrofit did not jacket and strengthen masonry columns on the second-floor balcony or add supports below the masonry columns. Without strengthening these masonry columns, in a larger earthquake the columns could crumble, leaving the overhanging ceiling and floor slabs unsupported and in real danger of collapsing during the earthquake or when students filed out to evacuate.

A retrofit of a rubble stone school in Rasuwa fared even worse—it completely collapsed. The block had been retrofitted by a major INGO using stitch banding technology and the community had been told the school would be safer than any new construction. The project included little training and oversight and even less adaptation to the limitations of the brittle stone building material. The donor organization sent a trained mason to the site for only two days to train local workers, none of whom had professional training as masons. During the middle of the construction process, the donor’s engineer came only once, briefly. Local workers found it impossible to adapt the stitch band retrofitting technique to stone masonry; they simply could not drill through the stone walls to stitch bands together, but the project implementation had no plan for adjusting the technology or discontinuing an unsafe solution. The result was a catastrophic collapse (Figure 7.5). The school principal captured and showed us on his smart phone how the donor-funded retrofit of his stone-and-mud-mortar school in Rasuwa did not prevent collapse in the earthquake. The left of Figure 7.5 was before the earthquake and to the right is just after the earthquake. The rubble had been removed by the time of the survey. Little training of masons and nearly non-existent technical oversight ensured that when masons struggled to implement the retrofit design, the problems were not caught and rectified. The principal estimates 120 out of 140 students and staff would have died. Had technical experts been involved in community outreach, they may have better understood the challenges of stone retrofit in a remote village and may have modified or abandoned the project for something more likely to result in a safe school.

Where local masons were appropriately trained and where trained engineers oversaw the construction practice by very frequent visits or continuous onsite presence, schools performed beautifully. They were completely undamaged and few signs of poor construction practice were evident. In Figure 7.6, the first was built without technical

support; the second was built after the community was given an orientation on earthquake-safe construction and local masons were trained in safer construction techniques. An engineer and lead mason, both with experience in earthquake-safe school construction, carefully oversaw the process. After the earthquake, the second school was operational; even the terrace had been covered and converted into a makeshift workshop for the local community. Clearly, the social support of training and oversight are crucial to achieving safe school construction in Nepal.



*Figure 7.5: Complete collapse of retrofitted school building in Rasuwa*



*Figure 7.6: Two neighbouring schools in Sindhupalchowk both built through international donor support but taking different approach of community outreach for technology transfer*

## **7.5 Performance of Reinforced Concrete Frame School Buildings**

Reinforced concrete school buildings in Nepal do have infill walls of unreinforced brick or stone masonry as exterior walls or interior partitions between classrooms. During the earthquake, many cracks developed where infills were connected with beams and columns. Others developed more noticeable damage at corners or even diagonal shear cracks. At the schools observed, the infill walls did not have the vertical or horizontal reinforcing steel to support them that is common practice prescribed by international building codes and NBC as well. When they cracked, as is expected in an earthquake, they became unstable because of the lack of reinforcing or other means of holding the walls in place.

These infill wall cracks, although considered minor damage from a structural engineering perspective, were a serious problem in schools (Figure 7.7). Teachers and

principals would demonstrate by pushing on the cracked walls, causing the walls to visibly move. With the risk that these walls could topple over and crush occupants in large aftershock or future earthquake, many schools with infill wall damage were given 'red tags' by Ministry of Education inspectors. A seemingly minor damage relegated untold thousands of students and staff to temporary learning spaces and tents.

Two ubiquitous school template designs approved by the Ministry of Education performed particularly poorly. The first was a metal frame supporting a corrugated metal roof, a design originally developed by a major bilateral development assistance agency. While the metal frame and roof were undamaged, the communities report that they were told to build exterior walls in whatever local material was available.



*Figure 7.7: School building in Bhaktapur (Kathmandu Valley) experienced only moderate shaking, but it was deemed unsafe.*

In semi-urban and urban areas, communities built unreinforced brick walls around the frames; in rural areas, they often used stone and mud to build the walls. A review of the design drawings of one of these structures does show detailing for a reinforced concrete lintel band on the top of the walls and reinforcing at wall connections. However, these elements of the design were not observed in any of the six metal-frame school blocks we assessed. In moderate to high shaking, these walls partially or completely collapsed and would have unnecessarily killed children had school been in session. A school building visited in Bhaktapur had experienced only moderate shaking, but it was deemed unsafe for school use because unreinforced partition walls separated from the reinforced concrete frame and became unstable. Damage to unreinforced partition or infill walls can injure or kill students. The safety of these walls is routinely ignored by engineers and communities alike.

## **7.6 Major Contributing Factors to Severe Damage of RC School Buildings**

While damage to school buildings that have inherent weakness due to the presence of unreinforced masonry walls and other irregularities is widespread, severe damage and



collapses occurred also in reinforced concrete school buildings that were supposed to perform better. A major factor that can be attributed to the severe damage and collapse, even at low intensity of shaking, include lack of lateral load-resisting capacity of these buildings, particularly at the bottom-storey level. It was observed that most of the heavily damaged RC school buildings sustained the damage only at the ground floor. Upper storeys remained intact unless the building lost the complete support that triggers collapses. This case is more prevalent in school buildings compared to residential homes, since the seismic weight of school buildings is higher due to thicker walls and slabs as well as due to the presence of large non-structural items like furniture. Figure 7.8 shows an example of this case from Janajagriti Secondary School in Sindhupalchowk. Infill walls and reinforced concrete columns were severely damaged at the first-floor level of two-storey reinforced concrete buildings. It appears that the seismic capacity at the first floor of this non-ductile reinforced concrete building simply did not meet the base shear generated by the shaking interacting with the heavy mass from roof, floor and walls.



*Figure 7.8: Heavy damage in Jana-Jagriti School, Sangachowk, Sindhupalchowk*

Another common deficiency in reinforced concrete school buildings that led to damage is a violation of seismic design principles. In the 9-storey reinforced concrete building at DipJyoti School in Kathmandu, the amount of longitudinal and shear reinforcements was modest, but the size of the concrete beams in the frame is significantly larger than the column, forcing the hinge formations at the column ends and leading to the complete collapse of the building (Figure 7.9). A typical size of a column was 300 x 300 mm, whereas the rigidly connected beam had a depth of 425 mm. This created a strong beam–weak column condition which resulted in high stress concentrations in column ends. In addition, the beam reinforcement detailing –column joints– were found non-compliant to standard seismic detailing.



Figure 7.9: Pancake collapse of reinforced concrete building at DipJyoti Secondary School, Kathmandu

### **7.7 Performance of Conventional Stone Masonry School Buildings**

Rubble stone construction in schools is a vexing problem. It is a common local material and essentially free; in many mountain regions, it is the primary construction material for schools and houses. Yet to be used in school buildings, it must be at least life-safe, since attendance is mandatory and safe evacuation of all students during shaking is impossible.

Most of the stone houses collapsed in the communities we surveyed. Most schools built with stone and mud mortar infill or load-bearing walls also collapsed, including the retrofitted school (albeit without appropriate training and oversight). Only when rubble stone was used with cement mortar and as an infill wall for a reinforced concrete frame school building, did we observe rubble stone that had not partially or completely collapsed. In Figure 7.10, a teaching resource centre on school grounds was built with stone and mud mortar. The masons employed earthquake-safety measures, such as a reinforced concrete lintel band and vertical reinforcement in the walls. However, even with these measures, the heavy shaking in Sindhupalchowk caused the stone building to collapse swiftly and completely. It may be difficult to rebuild safe schools out of this brittle material unless alternative technologies are developed and tested and extensive mason training and strict oversight are implemented during construction. A rubble-stone teaching resource centre co-located on a school site provides additional reason for caution. Even though it had been built with the earthquake-safe construction techniques commonly advised for load-bearing stone and brick construction, the resource centre completely collapsed. The resource centre had a lightweight roof, a reinforced concrete lintel band, and vertical reinforcement in the walls, though it did not appear to have a sill-level band or corner stitches.



Figure 7.10: Complete collapse of stone masonry teaching resource centre building with concrete bands

The widespread rubble-stone collapses, even in a case where a lintel band and vertical reinforcement had been used, suggests that constructing safely with rubble stone is fraught with difficulties. Further research is needed to understand how other rubble stone schools with earthquake-resistant features fared and what technical and social interventions seem to have worked well. However, until further testing or comprehensive field assessment, extreme care should be taken in building infill or load-bearing walls with this material in permanent, transitional, or temporary school buildings. Further, even if safe and appropriate technologies for rubble stone are identified, school reconstruction with this material will need to be carefully supported with robust programs for training, oversight and community outreach so that safety is achieved in actuality and communities can trust that these stone buildings will not collapse.

## 7.8 *Non-structural Damage in Schools*

It was observed that non-structural components in schools sustained significant damage in the event. Even in schools that had only minor or no significant damage to structural elements, damage to partition walls and to functional components like computers and science laboratory equipment were common. School staff told us that they found shelves used for document archives, bookshelves, computers and science lab equipment tipped over or slipped onto floors when they come back to school after the main shock event. Classroom furniture was, however, not affected, although many pieces shifted. Figure 7.11 shows a computer damaged during the earthquake in a school located in a northern suburb of Kathmandu.





*Figure 7.11: Damage to a computer in a science lab at SahidGhat School, Sundarijal, Kathmandu*

At the same event, there was also evidence of effective mitigation measures taken to reduce the impact of shaking to non-structural components in school buildings. Schools that had implemented comprehensive school safety measures performed well in aspects of non-structural safety too. Bal Bikash Secondary School in Alapot, the same village as SahidGhat School, where all the book cases and computer and science lab equipment were destroyed, saw no damage to non-structural items, as they were securely fastened to walls. The mitigation measures were simple, including such measures as anchoring of shelves to walls by angle clips and running rope across the bookshelves. In Figure 7.12, the principal of Bal Bikash School showed how angle clips, installed as part of the non-structural safety, restrained movement of bookshelves in his office.



*Figure 7.12: Principal of Bal Bikash Secondary School shows the effectiveness of non- structural mitigation employed in his school*

## 7.9 Use of Schools as Community Shelters in the Aftermath

We visited some schools that were part of the NSET's comprehensive school safety program that encompasses all three aspects of safety: safety of educational facilities including protection of structural and non-structural items; establishing disaster preparedness plans and running drills; and community outreach for earthquake safety education that also utilizes such physical interventions as retrofitting of buildings. Bal Bikash Secondary School (shown in Figure 7.13) was one of the several schools that took part in the program. It was observed that the impact of such comprehensive programs reached beyond the physical protection of school facilities. In fact, we observed that the program helped to build good social capital around the school, making a positive impact on community outreach. School staff and parents described how for about a month in the aftermath, when all schools in the earthquake-affected area were closed, the school building was used as temporary shelter for the community. The fact that even when their homes were not damaged in the main event, following the earthquake thousands of people in Kathmandu camped in the streets out of fear from aftershocks. But a case where a seismically upgraded schools was used with confidence by the community as a shelter shows that schools can be a good back-up for an emergency, and people can have something to trust in those uncertain and chaotic times. This success story, however, resulted from getting community trust through a community-based approach with several such outreach programs as parent orientation, mason training and social auditing.

There was a contrasting case in Bhaktapur, where a school was retrofitted with no involvement of community. No parents had good knowledge of the retrofit nor the trust to come to the school for shelter in the aftermath. In fact, they complained that the community was not informed about the school retrofit techniques that could be applied to their homes to reduce the impacts of earthquake shaking. Clearly, this was a missed opportunity to utilize the seismic upgrading of schools to influence the surrounding community for mitigation measures.



*Figure 7.13: Bal Bikash Secondary school, Alapot, was used as community shelter for about a month in the aftermath of the earthquake.*

## **7.10 Summary**

Nepal's education sector was severely impacted by the 2015 Gorkha Earthquake. Majority of school buildings in districts which were hardly hit by the earthquake collapsed. It is estimated that several thousands of young lives would have gone in peril, should the earthquake had happened on a school day. Many schools of unreinforced stone masonry construction sustained either severe damage or collapse. Also, unreinforced brick or stone infill walls in RC frames were the primary cause of heavy damage in school buildings, which were "red tagged" as unsafe for immediate re-occupancy. Some school buildings which were retrofitted by following simple retrofit methods generally performed well. The observations showed that even a simple seismic retrofit method when executed with enough technical oversight and technology transfer to the community can result in a safe school, and it also promotes the use of earthquake-safe housing technology within the community.

## **7.11 References**

Bothara, J.K., Guragain, R. and Dixit, A. (2002) Protection of Educational Buildings Against Earthquakes: A Manual for Designers and Builders. National Society for Earthquake Technology - Nepal (NSET), Kathmandu, Nepal

Bothara, J.K., Pandey, B. and Guragain, R. (2004) Seismic Retrofitting of Low Strength Unreinforced Masonry Non-engineered School Buildings, Bulletin of New Zealand Society for Earthquake Engineering, Vol. 37, 1, pp. 13-22

Nepal Sector Reports (2015) Nepal Earthquake 2015 Post Disaster Needs Assessment – Volume B: Sector Reports. Government of Nepal, National Planning Commission, Retrieved from [www.gfdr.org/sites/gfdr/files/WB\\_UNDP\\_PDNA%20Community\\_SP\\_FINAL.pdf](http://www.gfdr.org/sites/gfdr/files/WB_UNDP_PDNA%20Community_SP_FINAL.pdf)

Dixit, A. and Pandey, B. (2003) School Earthquake Safety Program in Kathmandu: A Case Study of Risk Reduction Effort in Public Schools. Proceedings, Conference on Disaster Mitigation and Urban Infrastructure Financing in Asia, Colombo, Sri Lanka



## 8 Performance of Cultural Heritage Buildings

Svetlana Brzev<sup>1</sup>

### 8.1 Overview

Nepal is home to a significant number of heritage structures with cultural and/or religious value, most of them located in the Kathmandu Valley. These structures include private residences, monasteries, palaces, shrines, temples, stupas and other monuments. Seven groups of monuments and buildings within the Kathmandu Valley are recognized as the UNESCO World Heritage sites, including: Durbar Squares of Hanuman Dhoka (Kathmandu), Patan and Bhaktapur, the Buddhist stupas of Swayambhu and Baudhdhanath, and the Hindu temples of Pashupati and Changu Narayan (UNESCO, 2016). According to the Government of Nepal (NPC, 2015), the initial assessment indicated that 2,900 heritage structures were damaged and/or collapsed in the 2015 earthquakes. Monetary damage associated with the loss of heritage structures was estimated at \$US 170 million. This is a relatively small fraction of the total earthquake loss estimated at \$US 7 billion; however, for the people of Nepal and the entire world, there is a tremendous nontangible loss associated with the religious and cultural value of these structures. These sites were the major tourist attractions for foreign visitors, with tourism being one of the top sources of employment and income for the population of Nepal. The CBC (2015) offers good video coverage of the effects of the 2015 earthquake on cultural heritage structures in Nepal, and a report on the seismic performance of heritage structures was prepared by EERI (2016).

In general, cultural heritage structures, both temples and buildings, were built with adobe or burnt clay brick masonry walls laid in mud mortar, but some temples were built of stone masonry construction. Many adobe structures were severely damaged or collapsed entirely at localities subjected to high ground shaking, including notable temples and palaces. Some significant heritage sites, such as Kathmandu Durbar Square (Figure 8.1), suffered more damage than other sites (Patan and Bhaktapur). Stone masonry temples performed better than adobe or brick masonry temples at the same site. For example, the Krishna Temple, a notable 17<sup>th</sup> century three-storey stone masonry temple at Patan Durbar Square, remained undamaged while adjacent brick masonry pagoda-style temples suffered extensive damage or collapsed (Figure 8.2a). The five-tiered Niyatapola Temple at Bhaktapur Durbar Square, constructed of timber and brick masonry, remained undamaged in the earthquake, although several other temples of the same typology collapsed (Figure 8.2b). Several other important heritage structures at different locations survived the earthquake without damage. It should be noted that several heritage structures that experienced severe damage or collapse in the 2015

---

<sup>1</sup> British Columbia Institute of Technology (BCIT), Vancouver, BC, Canada

earthquake remained undamaged in the 1934 earthquake (magnitude 8.0). The 1934 earthquake caused a significant life loss and damage in Nepal, however it did not affect the heritage structures to the same extent as the 2015 earthquake.

The CAEE team visited several important heritage sites, including the Durbar Squares of Kathmandu, Patan and Bhaktapur, and the Swayambhu complex. The team also visited a few smaller settlements with heritage value, such as Sanku. Key observations from these visits are summarized in this section. The selected heritage sites of Swayambhu and Kathmandu Durbar Square are described in detail. The observations contain information about construction practices and damage patterns for selected heritage structures at these sites; however, these structures are considered to be representative of heritage structures found at other sites in Nepal.



a)



b)

Figure 8.1: Durbar Square at Kathmandu: a) before the earthquake in 2008 showing three-tiered temples (Source: Travel 2008) and b) after the 2015 earthquake which caused the temple collapse (S. Brzev)

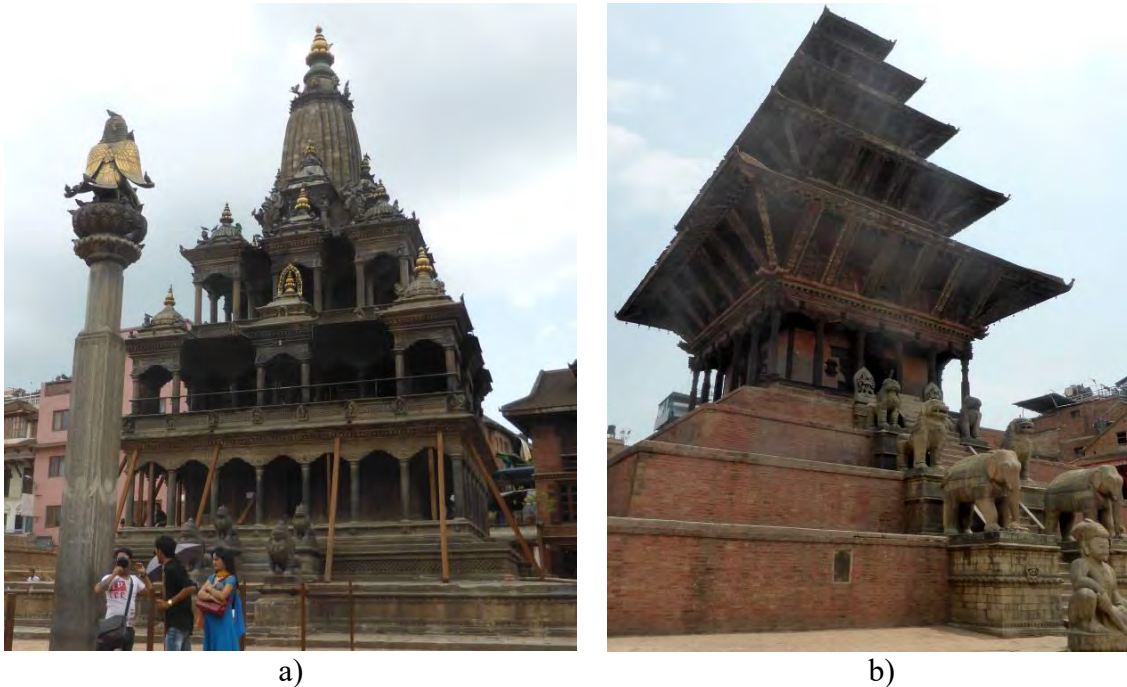

Figure 8.2: Examples of notable temples that performed well in the 2015 earthquakes: a) Krishna temple, Patan Durbar Square and b) five-tiered Niyatapola Temple, Bhaktapur (S. Brzev)

## 8.2 Swayambhu

The UNESCO World Heritage Site of Swayambhu is one of the oldest religious sites in Nepal and is revered both by Buddhists and Hindus. It was founded at the beginning of the 5<sup>th</sup> century CE on top of a hill in the middle of Kathmandu Valley. A legend says that once the Kathmandu Valley was a lake in which Swayambhu hill existed as an island. The complex consists of a stupa, several shrines and temples, and a monastery complex (Figure 8.3). The central monument within the complex is a stupa, a hemispherical memorial enshrining the relics of Buddha. The stupa has Buddha's eyes and eyebrows painted on it (Figure 8.4a). The stupa remained mostly undamaged in the earthquake, except for some cracking observed in the hemisphere portion, which is a solid filled structure of dry laid material with a plaster coating (Figure 8.4b). Some damage was reported in its top metal portion (parasol) which is leaning to the right. However, many other structures within the complex were damaged and/or collapsed. It is believed that the topology (top of the hill) contributed to the damage of Swayambhu. Some evidence of slope instability was observed in the vicinity of the stairs (Biggs, 2016).

At the time of the visit (June 16, 2015), demolition of one of the buildings of the Karmapa's Swayambhu Monastery (Figure 8.5) was in progress (labelled as 8 on the site map Fig. 8.3b).





a)



b)

Figure 8.3: Swayambhu complex, Kathmandu Valley: a) a bird's-eye view of the complex after the 2015 earthquake (Source: CBC) and b) a site map (Source: Diamond Way Buddhism Foundation)



a)



b)

Figure 8.4: Buddhist stupa at Swayambhu: a) an overall view and b) minor cracking observed at the domed portion of the stupa (S. Brzev)



a)



b)

Figure 8.5: Karmapa's Swayambhu Monastery: a) before the 2015 earthquake (Source: Diamond Way Buddhism Foundation) and b) demolition in progress in June 2015 (S. Brzev)

A few other monastery buildings within the Swayambhu complex were also heavily damaged, including the Drukpa Kagyu Monastery shown in Figure 8.6 (labelled as 13 on the site map Fig. 8.3b). These buildings were of unreinforced brick masonry construction with mud mortar, which resulted in a low masonry shear capacity. The buildings had timber floors and roofs that were not adequately anchored to the walls and lacked structural integrity. This is a common deficiency in these kinds of masonry buildings and a possible cause of the severe damage that the buildings experienced. The Drukpa Kagyu Monastery building was also characterized by an open front side, both at the ground floor (timber frame) and the upper floor with ornamental windows, which may have increased the seismic vulnerability of the building. It is expected that the topography (hill location) may have caused higher shaking intensity at Swayambhu compared to the adjacent sites at the base of the hill.



a)



b)

Figure 8.6: Drukpa Kagyu Monastery damage due to the 2015 earthquake: a) a view of the side façade of the building and b) a front view (S. Brzev)



Pratappur and Anantpur are important Hindu temples located on the north and south sides of the stupa (labelled as number 11 and 10 respectively on the site map Fig. 3b). The temples were originally built by King Pratap Malla in 1654 and are characterized by very similar dimensions and construction practices. Pratappur temple suffered damage due to a fire in 2003 and lightning in 2011 (UNESCO, 2011) and was subsequently rehabilitated (Figure 8.7a). There is no evidence of any significant renovations to the Anantpur temple. The Pratappur temple performed well in the 2015 earthquake (Figure 8.7b) compared to adjacent buildings but suffered damage at the plinth level. However, the Anantpur temple experienced heavy damage and its upper portion collapsed (Figure 8.8).



Figure 8.7: Pratappur temple: a) before the earthquake in 2011 (UNESCO, 2011) and b) after the 2015 earthquake—the temple can be seen at the rear of the photo (S. Brzev).

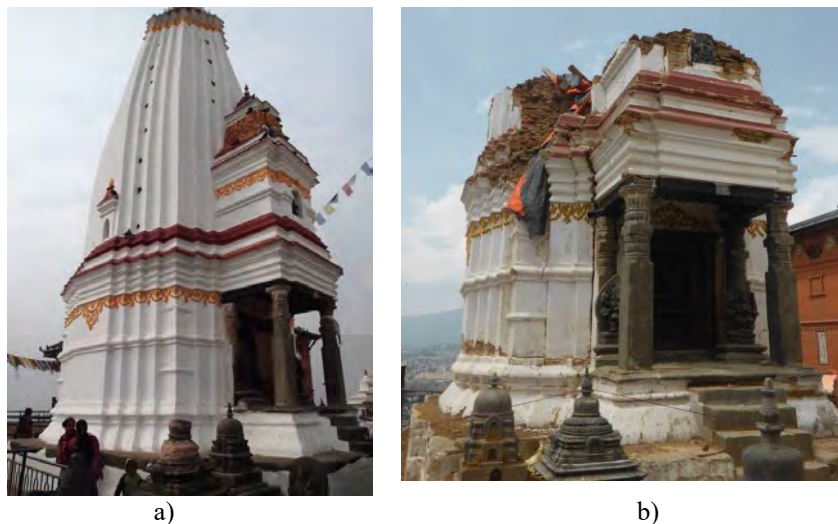

Figure 8.8: Anantpur temple: a) before the earthquake in 2013 (Catbird, 2013) and b) after the 2015 earthquake (S. Brzev)

Pratappur and Anantpur represent the type of Hindu temple known as a *sikhara* (“mountain” in Sanskrit), which is characteristic for the temples in Northern India. These temples have an elongated roof, usually with a parabolic profile. The temples have an octagonal base with maximum dimension of 5.2 m and a perimeter of about 18 m. The



overall height above grade is about 17.0 m (these measurements of Pratappur temple were taken during the visit). The base of the temple has a hollow cross-section with a room size approximately equal to one-half of the outer size. The proportions of sikhara temples are based on the ancient Hindu rules (Tiwari, 2009). The walls were of brick masonry construction. It is believed that mud mortar was used in the original construction, but an exposed masonry portion indicated the use of lime-putty mortar (Figure 8.9). Brick dimensions in the damaged portion of the Pratappur Temple were 210 x 140 x 60 mm (length x width x thickness), which are different from the dimensions of contemporary bricks used in Nepal (230 x 115 x 75 mm).



Figure 8.9: Exposed masonry construction at Pratappur temple: a) brick masonry in mud mortar at the plinth level and b) brick masonry in the lime surkhi mortar (S. Brzev)

Figure 8.10a) shows the condition of Pratappur temple after the 2015 earthquake. The temple experienced damage at the plinth level, while the upper portion of the structure remained undamaged. The damage was uniform around the perimeter at the base level, and was in the form of horizontal cracking and some crushed or dislocated bricks (Figure 8.10b). This form of damage is characteristic of a sliding shear failure mechanism that is common in masonry structures subjected to relatively low gravity-induced axial compression and high lateral forces. In this case, there was no sign of movement at the base.

Figure 8.11a) shows the condition of Anantpur temple after the 2015 earthquake. The roof of the temple collapsed. Significant cracking was observed in the bottom portion of the temple, which can be explained by the limited shear capacity of masonry walls. The temple was constructed using adobe bricks and mud mortar (Figure 8.11b). This is different from the Pratappur temple which was constructed using burnt clay bricks. The difference in masonry shear strength might have resulted in different failure mechanisms in the two adjacent temple structures—since they had similar geometry and were originally built at the same time.



a)



b)

Figure 8.10. Damaged condition of Pratappur temple after the 2015 earthquake: a) a view of the temple showing the exposed masonry at the plinth level and b) a detail of the damaged masonry plinth (S. Brzev)



a)



b)

Figure 8.11: Damaged condition of Anantpur temple after the 2015 earthquake: a) a view of the side façade showing diagonal shear cracks and b) a detail of the damaged masonry wall (S. Brzev)

A sikhara-type shrine was observed at a location close to the Pratappur temple (Figure 8.12a). The proportions are the same, but the perimeter is 5.8 m, which represents a 1/3<sup>rd</sup> scale of Pratappur temple. The overall height above grade is 4.5 m. The wall thickness was 38 cm. The shrine remained undamaged during the earthquake. The CAEE team members took field measurements of the temples at the Swayambhu complex (Figure 8.12b).



Figure 8.12: A sikhara-type shrine close to Pratappur temple: a) an exterior view, and b) CAEE team members Upul Atukorala and Bishnu Pandey taking field measurements of the shrine (S. Brzev).

### 8.3 Kathmandu Durbar Square

The Durbar Squares in Nepal's Kathmandu Valley are historic urban centres with palaces, temples and public spaces, all originally built between the 12<sup>th</sup> and 18<sup>th</sup> century. The three Durbar Squares (at Kathmandu, Patan and Bhaktapur) have been recognized as UNESCO World Heritage Sites for their global importance. Many heritage structures were destroyed in past earthquakes and had to be rebuilt. Once again, some of these monuments were severely affected by the 2015 earthquakes. At Kathmandu Durbar Square, nine temples completely collapsed and another 20 monuments were partially damaged. Two temples at Patan Durbar Square and three temples at Bhaktapur Durbar Square also collapsed. Many damaged heritage structures were braced to prevent collapse at the time of the CAEE team's visit in June 2015, as shown in Figure 8.13. This section describes the seismic performance of heritage structures at Kathmandu Durbar Square. The map of the square is shown in Figure 8.14.



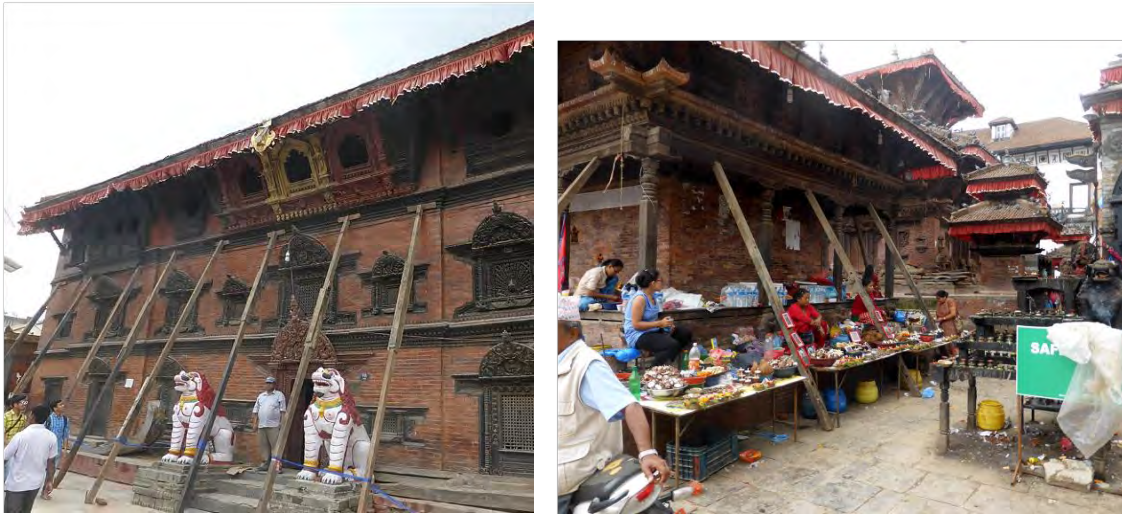

Figure 8.13: Damaged heritage structures at Kathmandu Durbar Square after the 2015 earthquake (S. Brzev)

The Hanuman Dhoka is a complex of structures within the Royal Palace of the Malla Dynasty, which occupies a significant portion of the Durbar Square. Its construction started in the 16<sup>th</sup> century, but it was expanded in the 17<sup>th</sup> and 18<sup>th</sup> century. The royal family lived in the palace until the end of the 19<sup>th</sup> century. A portion of the palace is used as a museum. Figure 8.15a) shows the partially collapsed southern wing of the palace (originally destroyed in the 1934 earthquake and rebuilt c. 1935). It appears that the palace had adobe masonry walls in mud mortar, as exposed in Figure 8.15b). The palace had a timber floor and roof structure and sloped roofs with tile roofing. There is no mechanical connection between the floors/roof and the supporting walls, only friction. This is typical for older URM buildings and contributed to seismic vulnerability of these buildings and the resulting damage in the 2015 earthquake. The Basantpur Tower (see map Figure 8.14) also collapsed, and the damage is illustrated on Figure 8.16.

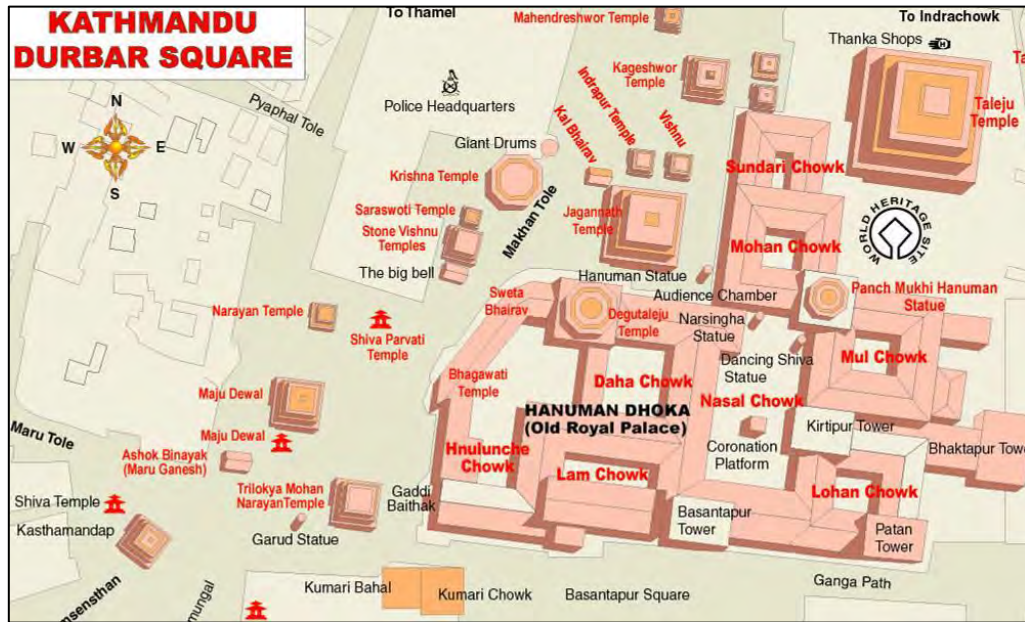

Figure 8.14: Map of Kathmandu Durbar Square ([www.digitalhimalaya.com](http://www.digitalhimalaya.com))



a)



b)

Figure 8.15: Hanuman Dhoka Palace at Kathmandu Durbar Square: a) a view of the south façade from the Basantpur Square (which was rebuilt after the 1934 earthquake), and b) a view of the palace from the courtyard





Figure 8.16: Severely damaged Basanpur Tower, Kathmandu Durbar Square (credit: David Biggs)

An 18<sup>th</sup> century shrine dedicated to Shiva and Parvati is located on the northern side of the Kathmandu Durbar Square (see Figure 8.17a). The shrine is a brick masonry structure with wooden elements. The lower part has a five-bayed carved wooden screen in the longitudinal direction, and a three-bayed wooden screen in the transverse direction. The upper portion has wooden brackets and a sloped wooden roof with clay tiles. The shrine was damaged in the 2015 earthquake. Extensive cracking was observed in the exterior masonry walls at the upper portion of the temple (Figure 8.17b).

Typical Hindu temples were built in a multi-tiered pagoda style. The temples usually have a square base and two-, three- or five-tiered roofs. Until the 16<sup>th</sup> century, these temples were two tiered until three-tiered temples built on a high platform were introduced to enhance temple earthquake resistance (Tiwari, 2009). It is interesting to note that the three temples that collapsed at the Kathmandu Durbar Square were three tiered and were built on a high base (Figure 8.18b). However, a three-tiered Bhimsen Temple at the Patan Durbar Square survived the earthquake without collapse. A five-tiered Niyatapola Temple at Bhaktapur's Patan Square also survived the earthquake (Figure 8.18a).





a)



b)

*Figure 8.17: Shiva and Parvati shrine before and after the earthquake: a) before the earthquake in 2008 (Travel 2008) and b) damaged temple after the earthquake (S. Brzev)*

These multi-tiered temples have a timber post-and-beam loadbearing structure and are braced by timber struts, and the panels are infilled with brick masonry. Ornamental doors are provided at the base, usually at all four sides. The walls are constructed in a staggered manner. The load from the upper-level walls is transferred downwards through the timber floor-structure supported by timber beams. The temples have one or more sloped timber roofs covered by clay tiles. The roofs are attached to the walls by means of timber struts and secured by means of wooden pegs.

The temple dimensions were proportioned based on ancient Hindu architecture rules that are unique to Nepal; that is, they differ from rules found in Indian Hindu temples (Tiwari, 2009). The Vishwanath temple at Patan's Durbar Square is an example

of a two-tiered temple. Figure 8.18b) shows a three-tiered Maju Deval temple in Kathmandu that collapsed in the 2015 earthquake.



Figure 8.18: Multi-tiered Hindu temples in Nepal: a) two-tiered Vishwanath temple, Patan after the 2015 earthquake (S. Brzev) and b) three-tiered Maju Deval Temple, Kathmandu in 2013--the temple collapsed in the 2015 earthquake (Wikimedia 2013).

Several two-tiered temples survived the earthquake without collapse. For example, the Vishwanath temple in Patan (originally built in 1627), experienced damage in the earthquake but did not collapse. It was observed that the brick masonry infill at the ground floor level was damaged (Figure 8.19a). However, some panels were braced by diagonal wooden struts that connected wooden posts and beams and had a positive effect on structural integrity (Figure 8.19b).

A smaller two-tiered temple at Kathmandu Durbar Square experienced damage in the earthquake but did not collapse (Figure 8.20a). The base of the temple was square with a 2.8 m dimension, and the overall height above ground was 5.7 m. The temple was built on top of a 500-mm-high plinth. The loadbearing structure of the temple consists of brick masonry walls and a timber floor and roof. The walls have two wythes, exterior and interior, which were not interconnected (each wythe about 100 mm thick). The exterior wythe was made of china bricks with very small mortar joints (Figure 8.20b) and separated from the wall and was about to collapse outwards (Figure 8.21a). The interior wythe was made of regular clay bricks bonded with thick mud mortar joints. An absence of a connection between the wythes at the wall intersection can be seen in Figure 8.21b). The space between the wythes was filled with brick rubble and mud. The bottom floor of the temple (about 2 m high) had four doors with heavy ornamental wooden frames. There is a heavy lintel beam at the top of each door level, but it is not connected with similar beams in other walls--thus the effect of a band is non-existent. However, at the floor-level there is a wide wooden band which is well connected at the wall intersections and provides structural integrity. Although small in dimensions, this temple reflects



construction practice of some other multi-tiered brick masonry temples in the Kathmandu Valley.

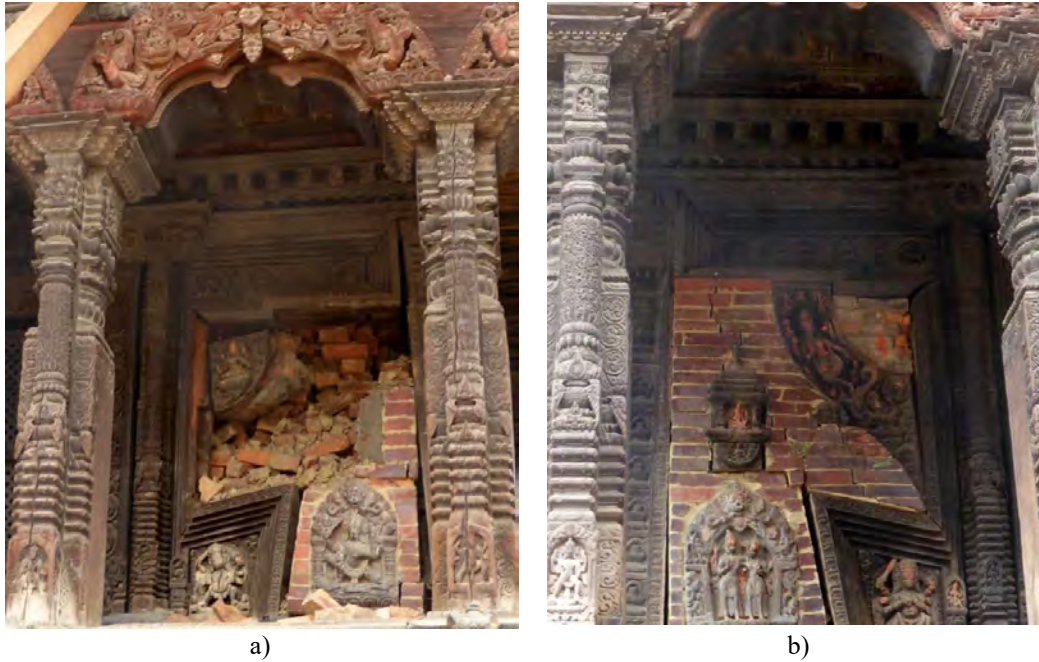

Figure 8.19: Damage of Vishwanath temple, Patan: a) a damaged panel showing dislocation and falling off of masonry and b) another panel that suffered minor damage—note timber bracing (S. Brzev).

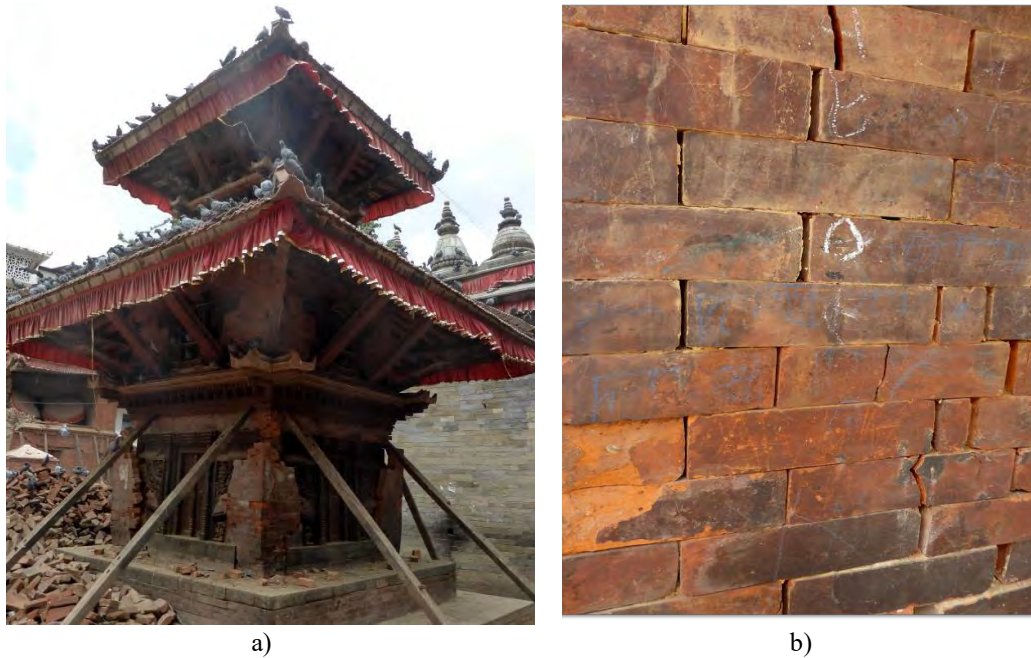

Figure 8.20: Damage to a two-tiered temple at Kathmandu Durbar Square: a) a view of the temple after the earthquake and b) an exterior brick masonry wall (S. Brzev)



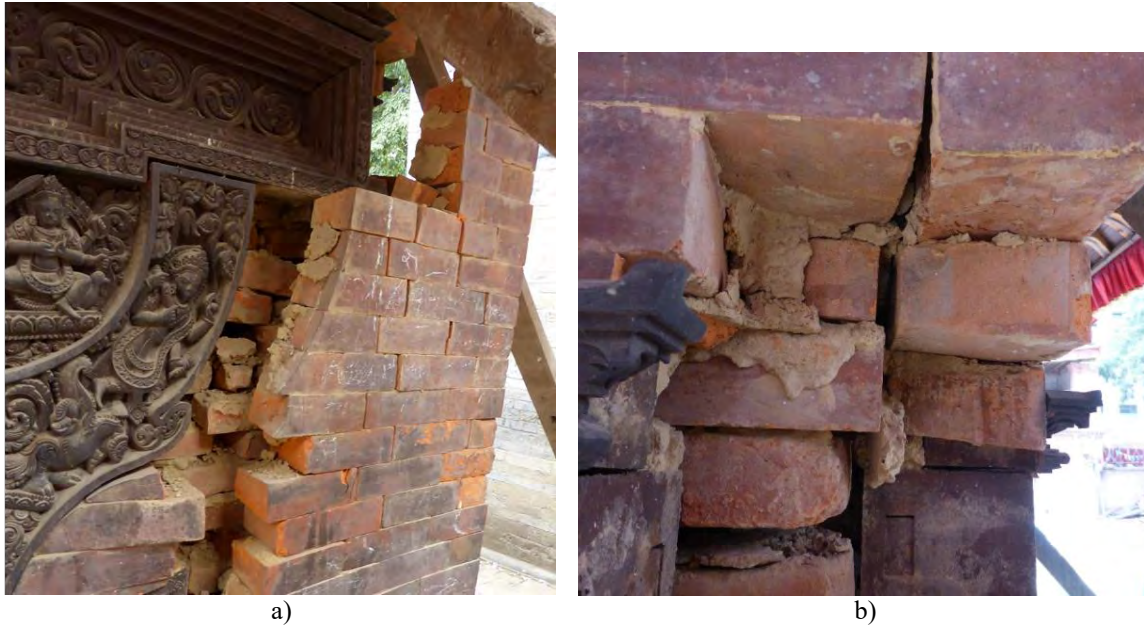

Figure 8.21: Damaged masonry wall in the temple shown in Figure 8.20: a) the separation of the exterior wall wythe and b) a detail showing an absence of the corner connection between interior wall wythes (S. Brzev)

#### 8.4 Summary

Depending on the site location, the 2015 Nepal earthquakes exposed thousands of cultural heritage structures to ground shaking of various intensities. Many adobe and brick masonry temples were either severely damaged or collapsed in the 2015 earthquake, but stone masonry temples performed well. Some multi-tiered Hindu temples were significantly affected by the earthquake. However, many temples withstood the earthquake effects without collapse due to the integrity provided by wooden structural components, although in some cases wooden components were deteriorated. Some buildings within palace complexes (such as Kathmandu Durbar Square) also suffered damage in the earthquake. A significant effort will be required to rebuild the collapsed cultural heritage structures in Nepal.

#### 8.5 References

Biggs, David (2016). Personal communication.

Catbird (2013). Kathmandu: Swayambunath, Catbird in South Asia, a blog (<https://catbirdinindia.wordpress.com/category/asia/nepal/kathmandu/swayambhu/ananta-pur/>)

CBC (2015). Saving Nepal's Heritage Sites. Canadian Broadcasting Corporation, May 7, 2015 <http://www.cbc.ca/player/play/2666649316>

EERI (2016). M7.8 Gorkha, Nepal Earthquake on April 25, 2015 and its Aftershocks. EERI Earthquake Reconnaissance Team Report. Earthquake Engineering Research Institute, Oakland, California.

Diamond Way Buddhism Foundation. (<http://swayambhu.buddhism-foundation.org/about/>)

NPC (2015). Nepal Earthquake 2015: Post Disaster Needs Assessment, Executive Summary, National Planning Commission, Government of Nepal, Kathmandu, available at: [http://www.npc.gov.np/en/download/major\\_reports](http://www.npc.gov.np/en/download/major_reports) (revision July 30, 2015).

Tiwari, S.R. (2009). Temples of the Nepal Valley. Himal Books, Kathmandu, Nepal.

Travel (2008). <http://www.mountainsoftravelphotos.com/Nepal%20-%20Kathmandu/Kathmandu%20Durbar%20Square/slides/Kathmandu%20Durbar%20Square%2005%2001%20Maju%20Deval,%20Narayan%20and%20Shiva-Parvati%20Temples.html>

UNESCO (2016) Kathmandu Valley. UNESCO World Heritage Centre (available at <http://whc.unesco.org/en/list/121/>)

UNESCO (2011). Lightning damages Pratapur Temple of Kathmandu Valley World Heritage site, Nepal. UNESCO World Heritage Centre (<http://whc.unesco.org/en/news/712>)

Wikimedia (2013). Le temple Maju Deval (Katmandou) (8602993846) by Jean-Pierre Dalbéra (<https://www.flickr.com/photos/dalbera/8602993846>)

## 9 The 2015 Gorkha, Nepal earthquake: Lessons for Nepal and Canada

**Bishnu Pandey<sup>1</sup>, Svetlana Brzev<sup>2</sup>, John Pao<sup>3</sup>, Sheri Molnar<sup>4</sup>, Upul Atukorala<sup>5</sup>,  
Pablo Riofrio Anda<sup>6</sup> and Carlos Ventura<sup>7</sup>**

This section discusses the main lessons learned from the 2015 Gorkha earthquake. These lessons are relevant both for Nepal and Canada.

### 9.1 *Lessons for Nepal*

#### 9.1.1 Seismology

The April 2015 Gorkha mega-thrust earthquake (M 7.8) occurred 80 km NW of Kathmandu at a depth of 15 km. The location could be anticipated, however all other seismological attributes did not match expectations. In particular, the shaking intensities and resulting damage in Kathmandu were lower than expected. There were very few strong motion recordings at the time of earthquake, hence ground motion parameters like attenuation could not be well characterized. From limited recordings, it is observed that the frequency content of the main shock is in the range of 0.2 to 0.25 Hz, with the site amplification occurring at 0.25 to 0.3 Hz. One of the reasons for apparently less damage is due to the fact that the majority of the buildings in Kathmandu fall outside these frequency ranges. However, some sites located west of Kathmandu showed site amplification. More strong motion stations are needed in Nepal. Those stations would constitute a good seismic network so that important information from future earthquakes is not missed. Micro zonation of major cities, like Kathmandu, would help improve land use planning for future earthquakes.

#### 9.1.2 Geotechnical Engineering

Geotechnical damage due to the 2015 Gorkha earthquake was limited. Fortunately, the PGAs and the number of cycles of significant shaking were comparatively low for an earthquake of this magnitude. However, had the earthquake-induced PGAs been closer to the design values (of the order of 0.45 g), if there had been a larger number of effective cycles of strong shaking corresponding to the established correlations with the magnitude

---

<sup>1</sup> British Columbia Institute of Technology (BCIT), Vancouver, BC, Canada

<sup>2</sup> British Columbia Institute of Technology (BCIT), Vancouver, BC, Canada

<sup>3</sup> Bogdonov Pao Associates, Vancouver, Canada

<sup>4</sup> University of Western Ontario, London, ON, Canada

<sup>5</sup> Golder Associates Ltd, Vancouver, BC, Canada

<sup>6</sup> Federal Aviation Administration, USA

<sup>7</sup> University of British Columbia (UBC), Vancouver, BC, Canada



of the earthquake, and if wet/saturated site soil conditions had existed in the valley, more widespread and destructive geotechnical damage could have occurred in Kathmandu Valley. This is an important lesson which can serve as a warning and encourage improved considerations of geotechnical effects in areas with liquefiable soils.

### **9.1.3 Transportation/Airports**

The main lesson learned from the Nepal earthquake for Nepal is that preparedness is key for an organized response. The TIA Airport Earthquake Emergency Plan was implemented during the earthquake and was effective to 95%, which is a major success. It was not possible to achieve the remaining 5% effectiveness due to lack of education and political interests. For example, some Nepal police officers left their posts at the airport to attend their personal needs, and it was very difficult to find replacements. Also, foreign governments used UN logistic cloister authorized earthquake relief to send large airplanes to evacuate their foreign nationals who were in no danger.

### **9.1.4 Non-engineered and pre-engineered low-rise RC buildings (designed according to MRT)**

Many low-rise RC buildings in the Kathmandu Valley and smaller towns in the affected districts were exposed to the 2015 Gorkha earthquake. In many cases, these buildings were characterized by one or more irregularities: open ground floor (storefront buildings), setbacks at the top floor, and vertical irregularity (variable building height) for buildings on sloped ground. It is expected that these buildings were either non-engineered (constructed by masons or petty contractors without input of qualified engineers) or pre-engineered, that is, they were designed in accordance to the Mandatory Rules of Thumb (MRT) (NBC 201:1994). In many cases MRTs were not followed in the design of non-engineered three-storey buildings, and in many cases the buildings were taller than three storeys although the sizes of key structural elements were not increased accordingly. These buildings posed a threat to public safety. There were no building inspection procedures in place to enforce adherence to proper construction standards.

Although some buildings of this type collapsed in the earthquake, most of them did not experience any damage. It is believed that the 2015 Gorkha earthquake, characterized by low shaking intensity, acted as a test for these RC buildings and provided a warning regarding possible consequences in the form of severe damage and/or collapse in a more severe future earthquake which is expected in Nepal.

### **9.1.5 Engineered medium- and high-rise RC buildings**

A formal structural engineering licensing process is currently not in place in Nepal. Such process is required to ensure that practicing structural engineers have minimum qualifications as a result of the combined education and experience. Furthermore, there is no formal building permit process which includes external and independent party reviews of the structural engineering design to validate adherence to the relevant building codes.

Nepalese authorities could consider North American professional practice in developing quality assurance process for engineered RC buildings. Such process has been in place for decades in cities located in high seismic regions of North America, such as

Vancouver, BC, Canada, and Los Angeles (LA), California, USA. The licensing and building design quality assurance processes in these cities is summarized below:

1. Professional engineer (designation P.Eng. in Canada and P.E. in the USA) is granted a license to practice after minimum 4 years of qualified experience in Vancouver, Canada (LA requires engineering examination).
2. An additional Structural Engineer (S.E.) license in California is granted after additional 2 years of practice and a further examination is required to demonstrate minimum seismic design knowledge. In Vancouver there is also an additional license (Struct. Eng.).
3. Every significant building project is designed and sealed by a licensed S.E who is legally the structural engineer of record taking full responsibility for the project.
4. In LA, upon submission to building authorities for building permit, an independent review is conducted by a qualified structural engineer in the building permit department, or an outside consultant who is hired by the department.
5. Building permit is granted upon satisfactory review of the design.
6. In LA, during construction, the owner is required to hire an independent quality control inspector (called deputy inspector), who is trained and licensed by the authorities, to conduct inspections on the contractor's work, including i) placement of reinforcement to ensure conformance to approved drawings, and ii) perform concrete tests on every pour to ensure conformance.
7. Contractors are properly trained to possess sufficient knowledge regarding construction of multi-storey RC buildings in high seismic zones.
8. Reinforcing steel supplier produces shop drawings for structural engineer's approval prior to fabrication.
9. Mill certificates for reinforcing bars are submitted to the structural engineer.
10. Changes must be documented and approved by the structural engineer.
11. Concrete shoring for floors must be designed by a qualified engineer.
12. Building inspectors working for building departments (municipalities) perform regular inspections to ensure high construction standards.

#### **9.1.6 Non-engineered unreinforced masonry buildings**

Unreinforced stone masonry is a prevalent type of rural housing construction in hilly regions of Nepal, because stone is the most accessible material for local communities. Unfortunately, this type of construction has major deficiencies with regards to seismic safety. Inherent vulnerability of multi-wythe random rubble stone masonry walls is due to a lack of integrity and proper connections at wall intersections, but it can be minimized through the use of seismic bands and improved wall-to-floor connections. There is a need to investigate and develop simple techniques, such as the use of gabion wire, polypropylene bands, external reinforcement etc. that could enhance the seismic safety of stone masonry housing.

### **9.1.7 Schools**

Had the 2015 Gorkha earthquake struck during a school session, that earthquake would have been known as one of the earthquakes with the highest child mortality due to the destruction of school facilities. Schools in Nepal are disproportionately vulnerable to earthquakes in comparison to other buildings and infrastructure facilities. Community schools that were built using local materials (e.g. stone) without any engineering input pose a significant seismic risk, as evidenced in the Gorkha earthquake. Several thousands of similar schools in other parts of the country are at risk from damage in future earthquakes. The Government of Nepal needs to make a significant effort to reduce the risk posed by the existing school buildings and ensure that new schools are built with earthquake-resistant system. Simple retrofitting techniques for schools can be used to minimize the risk of child fatalities during earthquakes. The design and construction of schools should also address the risk from collapse of walls in steel frame structures, which were in the past often considered as non-structural components in designs approved by the Department of Education

### **9.1.8 Heritage structures**

The 2015 Nepal earthquakes exposed thousands of cultural heritage structures to ground shaking of various intensities. Many adobe and brick masonry temples were either severely damaged or collapsed in the earthquake, but stone masonry temples performed well. Some multi-tiered Hindu temples were significantly affected by the earthquake. Some buildings within palace complexes (such as Kathmandu Durbar Square) also suffered damage in the earthquake. The main lesson is that a significant effort needs to be made by the Government of Nepal and other organizations to protect the heritage structures from the effects of future earthquakes in Nepal.

## **9.2 *Lessons for Canada***

### **9.2.1 Seismology**

The recorded ground motion of the April 25, 2015 megathrust earthquake in Nepal showed very high spectral values at 4 to 5 sec. periods that would match the periods of long period structures. The recorded PGA is significantly low for the given earthquake magnitude and given epicentral distance, but most of the energy is carried by long period waves. This finding may be of interest to Canadian seismologists.

The 2015 Gorkha earthquake has once again confirmed the importance of geotechnical considerations for all building structures, and especially those located in liquefiable soil areas.

### **9.2.2 Transportation/Airports**

The main lesson is that preparedness and awareness saves lives in any seismic event, moreover in an airport where large concentrations of people occur. Education on organizing airport evacuation, structural supports for secondary structures and an effective communication plan among other issues is very important to minimize injury and ensure an effective use of the available resources.



### 9.2.3 RC buildings

The main lesson is that non-ductile RC frame structures are at significant risk from damage or collapse in major earthquakes which are expected to occur in Canada (particularly West Coast). Although design and construction practices in Canada are more advanced than in Nepal, there are existing RC buildings without ductile detailing which were designed according to older code requirements and design and analysis approaches. These buildings should be evaluated for seismic safety and will likely need to be retrofitted to meet the current code requirements. Another lesson is that modern building codes for seismic design must be enforced to be effective. Structural design of important buildings must be reviewed by building officials or external experts for conformance with design standards to protect public safety.

### 9.2.4 Unreinforced masonry buildings

The 2015 Gorkha earthquake reconfirmed that the unreinforced masonry buildings pose a major threat to the built environment in developing countries with high seismic hazard. A lesson that existing URM building stock in high seismic hazard regions of the country is vulnerable and needs to be upgraded. There are many buildings in Vancouver and other high seismic regions that are constructed similarly to the brick buildings in Nepal. Municipalities need to provide incentives for building owners to upgrade vulnerable buildings in urban areas to protect public safety in the event of a major earthquake. The Canadian engineering community needs to be knowledgeable of available seismic retrofit methods for URM buildings to minimize seismic risk associated with this type of construction.

### 9.2.5 Schools

A major lesson from the 2015 Gorkha earthquake is that existing URM school buildings in seismic regions of Canada are at high risk from damage or collapse in future earthquakes. Cost-effective simple retrofitting techniques for URM schools such as the ones developed in British Columbia under the BC Ministry of Education's program which started in 2004<sup>1</sup> could be adapted to Nepal and other countries.

### 9.2.6 Heritage structures

The 2015 Gorkha earthquake has emphasized the importance of preserving cultural heritage structures, which have immense value for the country and the society. There are ongoing efforts in Canada to preserve heritage buildings, such as the Parliament Building Complex in Ottawa, and also heritage structures in other provinces. Many heritage buildings in areas of high seismic risk have been retrofitted, and many other buildings have been restored as a part of ongoing maintenance activities. These critical efforts for preserving the cultural heritage structures in Canada need to be continued.

---

<sup>1</sup> <https://www.apeg.bc.ca/For-Members/Professional-Practice/School-Seismic-Upgrade-Program>